



The
Shadowrun
Supplemental
Five

In this issue:

Jak Koke Interview
Expanding Prime Runners
SwiftOne Speaks
A Field Trip
And more!

Adam Jury
fro@lis.ab.ca

<http://shadowrun.home.ml.org>

From The Editor

Welcome to the fifth issue of The Shadowrun Supplemental. Once again, I feel this is an issue of growth for the magazine, adding several “full-time” staff members and also getting a good distribution increase.

It would be remiss not to give great thanks to Paolo Marcucci for the very generous donation of web page space on his server InterWare.it (Which also houses The Shadowrun Archive). The <http://shadowrun.home.ml.org> URL still works, along with the new URL at <http://www.interware.it/users/adamj>.

Without him, there would have been much hassle trying to get this issue distributed properly. The web page has also been re-organized and now contains more information, and should be updated more frequently.

In other news: With a little bit of weaseling, I managed to claim my work on TSS as ‘Special Projects 10’, an Alberta High School course. This means I get credits towards graduation for working on the magazine, as well as use of the schools computer resources without having to lie/cheat/steal or bribe.

And yet more news: The redistribution policy has changed. Please take a moment to read it.

More Thanks and Hellos

This list continues to grow. Hellos go to Gurth, Dvixen, Bull, Skye, Dawn, Tinner, Roxanne, Sunette, Rick, Pete, Adam, Elle (Oh expensive one!) and the usual anyone I forgot, and I know there’s a few of you.

Very special thanks to Jak Koke for providing us with some wonderful and thought provoking comments.

Big special thanks to Brett "SwiftOne" Borger and Barry Beldam, Jr. They are the lucky two who jumped on the open positions of Reviewer and Artist, respectively. I would also like to thank everyone else who applied.

The Shadowrun Supplemental Issue #5

Published November 15th, 1997

Editor: Adam Jury
fro@lis.ab.ca

Associate Editor: Dvixen
dvixen@coastnet.com

Artwork: Barry Beldam, JR.
Hades@mail.cgo.wave.ca

Writers:

Brett Borger
bxbl21@psu.edu
“SwiftOne Speaks”

—
The Kumquat
kumquat@onion.com
“Expanding Prime Runners”

—
Gurth
Gurth@xs4all.nl
“Field Trip”

—
Craig Rickel
Crickel@umr.edu
“Fun, Chemistry, and Shadowrunning”

—
Steven “Bull” Ratkovich
Chaos@ncweb.com
“QuickSilver Lightning Part 4”
“Target: Jak Koke”

—
The Cluttered Datastore Contributors:
Adam Jury fro@lis.ab.ca
Steven Ratkovich chaos@ncweb.com
Tim Bradley tbradley@nvi.net
NegativePulse@slurpee.net

Contacting the Editor and Submissions

I can be reached at fro@lis.ab.ca and fro@sara.cas.nwu.edu, first address preferred, please. I can also be contacted on the ShadowRN mailing list, and on Undernet #Shadowrun. Additionally, I can be reached via ICQ — my UIN is 2350330.

The TSS Productions web page at <http://shadowrun.home.ml.org> contains all the back issues, submission guidelines, and a few other things you may need to know. If you can't find what you're looking for, please do not hesitate to contact me.

Legalities

This magazine is in no way endorsed nor produced by FASA Corporation.

Shadowrun and Matrix, are copyrights of FASA (1997) Neither I, nor the authors of any individual pieces intend to infringe on FASA's intellectual property and rights. FASA has not read this material in advance, and as such, none of this material is approved by FASA.

The interviews with FASA staff and freelancers are of course partially produced by FASA employees, however, FASA still has nothing to do with this magazine or its articles, officially.

Copyrights

All contents are copyright (1997) by their original authors. I (Adam Jury) retain the copyrights over the compilation of material.

Redistribution

This magazine may be re-produced in another computer format only with permission from me. It cannot be archived on any other computer system or internet site without my permission.

Edited versions may not be distributed, it may be edited only for your personal use and within your own gaming group. IE: You can edit out the module if you want to print a copy to give to your players, but you can't edit out the module and put it on your web site.

Gaming Intelligence

(The staff and editor of TSS are not associated with Gaming Intelligence. We're just nice guys and like GI)

Gaming Intelligence is a free weekly newsletter sent out by email and archived on our Web site. It focuses on the gaming industry, specifically roleplaying, card games (collectible or not), miniatures/wargaming, play by mail, live-action, board, and related games. Every Monday, GI will arrive in your mailbox, bringing you the latest gaming news, product releases, feature articles, columns, and reviews.

To Subscribe: Send the message "join gi" to list-request@rpg.net or visit our Web site at <http://rpg.net/gi/>

Fun, Chemistry, and Shadowrunning

Spider Murphy - crickel@umr.edu

Few people realize the hidden potential of the science skills. Not only can these skills give you valuable information during a run, they can be used in between runs to manufacture valuable equipment - like that C-12 explosive everyone seems so eager to have. But explosives are not the sole province of chemistry.

One of the characters I played with recently was a molecular chemist. He specialized in the manufacture and manipulation of buckyballs. Buckyballs are an interesting material. Put together one way, they're the world's greatest lubricant - molecular ball bearings. Another and they become high-temperature superconductors. They can be filled with atoms of other material. They can be made magnetic with some minor tinkering. And to make monowire you just stretch it out.

Monowire is a wonderful tool all by itself. It's strong, flexible, and will cut through almost any material other than itself. My character used it to cut off door handles to discourage pursuit, to flatten tires of cars, and to rig impromptu pulley systems. At one point he even used it to fix an electric vehicle (he had some of the conducting variant on hand).

There are lots of other stuff you can do with chemistry. Thermite, Dikote, all sorts of acids, and hundreds of drugs - these are all things you can manufacture with chemistry. Given the proper equipment, well-played chemists can the match of any samurai.

Sure, Samurai are big, mean, tough. They have assault rifles, cyber limbs, move almost faster than thought, and they could polish off a SWAT team before breakfast. How could a mere scientist be a threat?

Play your scientist smart. Pick and choose your battles; don't let the enemy pick them for you. Set traps. Lots of traps. When you're being pursued, do everything you can to delay them. Weld doors shut with thermite. Throw slippery buckyballs onto the floor. Blows the street up if they're chasing you by car. Remember, lots of streets have subways under them.

Perhaps the best defense of all is being nowhere near the samurai. Sell items to get money and hire some mercenaries, and send THEM after the sammie. Or watch them until they leave their conapt, and lace it with bombs, monowire, you name it. Put one on the toilet. What self-respecting samurai checks the toilet for bombs?

Any character can be deadly when played like it. Don't be stupid. You can't go toe to toe with the guns, so don't even try. Hit them where they can't hit you back, and you'll live long enough to enjoy the yen.

Creating Prime Runners - Shadowrun Companion Expansion

The Kumquat - spamquat@juno.com

Ok, I was a little miffed at the vagueness of this section in the companion, as it further confuses Gamemasters who want levels of opposition appropriate to their campaign, and aren't satisfied by the archetypes presented in modules that are often painfully under-(or over-)powered for their PC's.

So I took their suggestions a step further, and playtested the NPC's created with this method, and they seem to work as they are supposed to. This is a fair amount of work for NPCs, so I advise you to use these rules to create only important NPC's for your campaign. If the NPC in question doesn't have a name or a personality at the start of the game system, use standard contact or archetype stats and fudge the numbers a bit. But if you want an unusual or important NPC, such as the individual characters' enemies, this should help you.

Getting Started - Create the NPC as you would a normal PC, with adjustments to the character creation tables as follows, and ignore maximums for ratings of items, starting skills, and so on.

Priorities For Prime Runners

Inferior (Not very prime..)

Priority	Race	Magic	Attributes	Skills	Nuyen	Force Points
A	Metahuman	Human Magician	20	27	700,000	33
B	Human	Adept/ Metahuman Magician	16	20	250,000	23
C	Human	Metahuman Adept	13	16	60,000	17
D	Human	None	11	13	3,000	13
E	Human	None	10	11	300	3

Equal

Use Standard Character Creation Table.

Superior

Priority	Race	Magic	Attributes	Skills	Nuyen	Force Points
A	Metahuman	Human Magician	42	50	1,250,000	63
B	Human	Adept / Metahuman Magician	30	42	500,000	44
C	Human	Metahuman Adept	25	30	115,000	31
D	Human	None	21	25	6,250	19
E	Human	None	19	21	625	6

Superhuman

Priority	Race	Magic	Attributes	Skills	Nuyen	Force Points
A	Metahuman	Human Magician	48	64	1,600,000	80
B	Human	Adept / Metahuman Magician	38	48	640,000	56
C	Human	Metahuman Adept	32	38	145,000	40
D	Human	None	27	32	8,000	24
E	Human	None	24	27	800	8

Ultimate

They don't need stats, silly.

A note about the above tables... you may be saying "Geez! 48 points for attributes! That's a bit powerful..." Well, of course it is. That is an "A" priority for a "Superhuman" character. An average attribute of 8 is rather high, but well within the absolute limit of $1.5 * \text{Racial Max}$. Whatever a Superhuman Prime Runner chooses as Priority A will likely be nearly ridiculous. These are the Sally Tsungs, Lord Torgos, and FastJacks of your campaign world, and should be treated as such... use them sparingly. And keep in mind, that some of the creatures/NPC's in certain FASA modules (I.E. Harlequin's Back) could EAT even a superhuman Prime Runner created using these rules.

Finishing off the character - Give the character a description, background, personality, and "loyalty", as is appropriate to your campaign. Edges and Flaws, if you use them, should also be made available to the Prime Runner, as well. (in fact, "Exceptional Attribute" is a must for Superior and Superhuman PRs) Also, keep in mind that certain PRs have loyalties to agencies within the SR world that can provide them with monetary resources well above and beyond the cash provided by character creation. If the Prime Runner is still underpowered due to the advancement of your PC's, then this is easily fixed.

Give the Prime Runner a number of Karma equal to the average total Karma attained by the runners, and use it to further initiate, make the stats and skills even higher, create allies, or whatever else suits the character.

How I got these numbers

This is an extrapolation of the rules presented by The Shadowrun Companion. The rules state that on an average, the stats of the PR should be a certain number higher or lower than each comparable stat of the PC's. I took the "A" priority for attributes and raised or lowered each by the number of points needed to make them "Inferior" or "Superior", etc... and then I raised or lowered Nuyen, skills and Force points, as well as the attributes for lower priorities by the same ratio. I finished it off with a fair amount of rounding numbers off, and voila! There are the tables. Mathematically, it may not be 100% sound, but every NPC I've used with this sytem and a fair amount of common sense, were just about perfectly balanced for the group I run.

The Cluttered Datastore

Various Authors

◆ Well folks, another installment of 'stuff'. Not much to say this time around, but enjoy — and I expect to be seeing from freaky hairstyles very soon, well, more than normal...

◆ NuDawn

Ruthenium Hair Implants [Class: Cyberware (Body)]

Virtually indistinguishable from normal hair, color can be either internally controlled via a ChromaSync SPU, or a datajack or short-range-wireless transmitter (supplied). As a bonus, replacement hair doesn't generally get fizzy, dirty, or unmanageable, nor does it grow :-)

Rating	Effects	Essence Cost	Cost	Legality	Street Index	Availability
N/A	N/A	—	1000¥	Legal	0.75	2/24 Hrs

PMP Hair Implants [Class: Cyberware (Body)]

Yet another application of the new PMP-fiber technology — Hair! No more bad hair days, no more time spent keeping every hair in place... a push of a button, or the twitch of a cybertriggered PMP SPU, and the natural-looking and feeling fibers of your hair will instantly assume any style desired, with as much (or as little) hold as you'd like. You can even download the latest styles from the Matrix Boutique! PMP tresses can even appear to grow or shrink up to a foot in length or more (maximum change of $\pm 10\%$ of base length) by carefully spaced micro-contractions and expansions.

Rating	Effects	Essence Cost	Cost	Legality	Street Index	Availability
N/A	N/A	0.05	1000¥	Legal	1.0	3/24 Hrs

R/PMP Hair Implants [Class: Cyberware (Body)]

The ultimate in cryo-chill! Wiz combo of the Ruthenium and PMP hair replacements, allows TOTAL domination of your 'doo! Blonde in a conservative cut for the halls of Corporate Power, then a head of dark, sexy mystery in a cryo-max style with a click of a button on your way to the clubs — it's easy with the R/PMP implant system.

Rating	Effects	Essence Cost	Cost	Legality	Street Index	Availability
N/A	N/A	0.05	5000¥	Legal	1.0	3/24 Hrs

◆ Someone I know uses this all the time. Although the tech is still a bit rough, it does what it says, and it may seem useless, but think about it: One day you're a brown haired guy running from the Star. Next day you have short spikey blond hair. Gee..

◆ Phro

PMP Musculature Lacing [Class: Cyberware (Body)]

Developed as a new application of muscle augmentation, this procedure utilizes PMP (programmable memory-plastic) to alter the density and shape of flesh and muscle as the mesh of plastic anchors and tiny sub-processors alters anchor points and containment. Alterations both subtle or radical are possible when the process is driven by sufficiently powerful software and extensive modifications. There are two main downsides with the process — it is inherently incompatible with bioware muscle augmentation in many ways — subtract the PMP/ML rating from the muscle Aug. rating to find the muscle augmentations effective rating, though if installed at the same time as Muscle Aug or Muscle Replacement 'ware, Essence cost for the PMP/ML is halved. Also, in use, the system draws heavily on the user, muscle cramps, fatigue, etc. are frequent (take the listed stun damage once per (Body*10 min)) Note that a system can always be used at a lower-than-max-performance, in which case bonus and penalties are as used. A level 1 system can make minor alterations to facial and physical structure, level 2 more drastic, level three systems can even alter the apparent sex or metatype of the user, particularly in conjunction with the PMP Bone-lace system. [NOTE: The "disguise" modifications listed for PMP usage are an increase to the target number to see through the "disguised" user's guise and recognize them as who they are. Other modifiers effect such a disguise normally, with PMP modifiers applying last.]

Rating	Effects	Essence Cost	Cost	Legality	Street Index	Availability
1	+2 Disguise, 1 Stun/*	0.8	45,000¥	5P-CA	1.0	6/12 days
2	+4 Disguise, 2 Stun/*	1.6	95,000¥	5-CB	1.5	12/16 days
3	+6 Disguise, 3 Stun/*	2.4	150,000¥	4-CC	1.75	14/18 days

*=(unaugmented Body * 10) min

PMP Bone-Lace [Class: Cyberware (Body)]

Applying the newly-approved Programmable Memory Plastics (PMP) to the proven techniques of bone-lacing, this implant encases the bone-marrow in an unbreakable but flexible weave of plastic that can alter to suit the users needs... while we can't promise miracles (No actual mass is lost or gained), an apparent increase or decrease of 5% height per level of PMP-lacing installed can be achieved (Of course, if you /gain/ height, you lose bulk, and vice versa). Note that use of this implant requires use of a PMP-SPU to calculate the altered muscular anchors, centers of mass, etc). Also note — once attained, any given state of bone-structure is stable, requiring no further energy to maintain, but, the change itself is horribly painful and even damaging: the user takes the listed physical damage for each change, and a "rating 3" change cannot be done as three spaced-out rating 1 changes, though if the user takes (1 hour * level of change)/Body, 1 pt of damage may be shifted to the Mental row. PMP/BL is also incompatible with normal bone-lacing, able to co-exist only with plastic bone-lacing of beta grade or higher, not functioning at all with any other forms.

Rating	Effects	Essence Cost	Cost	Legality	Street Index	Availability
1	+2 Disguise, 1 Dmg	0.5	35000	5P-CA	1.0	7/13 Days
2	+4 Disguise, 2 Dmg	1.15	100000	5-CB	1.5	13/17 Days
3	+6 Disguise, 3 Dmg	2.25	150000	4-CC	2.0	14/20 Days

PMP SPU [Class: Cyberware (Cranial)]

Surgical-grade Programmable Memory Plastic was a phenomenal breakthrough, but to accomplish the full range of it's miracles, you need MAJOR processing power. We've developed a proprietary algorithm for real time processing the way you need. Here are the SPU's you need to use our PMP-lacing lines.

NOTE: Bone or Muscle lacing will only function as the LOWEST of SPU and Lacing.

GreyJohn gets himself a R3 Muscle Lace, a R3 PMP-SPU, and finally a R2 Bone lace... the bone lacing functions at R2, the muscle lace at R3. If he'd only sprung for a R2 SPU, BOTH the muscle and bone lacing would function at R2. The sole exception is the R4 SPU — this gives a +1 to Disguise Target Number (for seeing through the disguise) if and only if both muscle and bone lacing are installed at R3 (not necessarily USED at that level).

Note that this configuration is required for any hope of reasonable emulation of other meta-races. Note: the PMP-SPU does not have onboard memory to contain the datafiles needed for successful alteration — such files occupy $2 * (\text{Body}^2)$ Megapulses for Bone-lace data and $3 * (\text{Body}^2)$ for Muscle-lace data per configuration, and the original muscle/bone configuration must be held in memory as well.

Rating	Effects	Essence Cost	Cost	Legality	Street Ind.	Availability
1	Needed for R1 PMP use	0.1	9000¥	5P-CA	1.0	7/13 Days
2	Needed for R1 PMP use	0.15	16000¥	5-CB	1.5	13/17 Days
3	Needed for R1 PMP use	0.2	27000¥	4-CC	2.0	14/20 Days
4	See Description	0.25	42000¥	3-CC	2.5	16/24 Days

ChromaSync SPU [Class: Cyberware (Cranial)]

The famous Stealth-suit-chip, declassified and designed for more wide-application use as a cyberchip (Hand held units available at same cost, due to reader, transmitter, etc.) Tying into an in-place ruthenium mesh, the ChromaSync locks colors down the way they should be. Note that the chip does NOT have on-board memory to store color-data, though dedicated memory can be installed at the same time as the chip for 1/2 Essence & NY costs. Memory requirements vary based on complexity and size: color/pattern-data for a pair of metahuman eyes takes a little under 1 Megapulses. A 3 foot long mane of hair, maybe 3 Megapulses

Duplicating the surroundings of a naked troll so that his body can blend like a chameleon-suit would require $7 * (\text{body}^2)$ Megapulses or more. Live/dynamic chameleon effects require double buffering the visuals, so 2x the above. Also note that real-time response degrades with SLD -- subtract the SLD from the target number to spot a chameleoned individual. On the bright side, a datajack can smoothly link a chameleon suit and ChromaSync SPU and triple the longevity of the suits power, as well as allowing more "visual" input to smooth the camouflage.

A rating 1 chip will hold a single, stable signal, maintaining color of any naturalness or complexity in a non-shifting pattern. (Neon tattoo's, permanent tan, etc.) This single pattern CAN be changed via data-jack reprogramming using normal target numbers and times based on the megapulses of the ChromaSync file.

A rating 2 chip can handle simple shifts such as switching between not-too-different presets (brown eyes today, or blue? tan skin outdoors, flawlessly-pale indoors, etc.)

Rating 3 chips can handle more complex preset conditions, down to detailed variations of hair, skin, eyes, etc. in mix-and-match datafiles.

Rating 4 chips, however, are required for the rapid, complex changes required for chameleon effects — note that human binocular vision qualifies as ONE video source towards those needed for chameleoning. Most R4CS-SPU's are, for that reason, tied directly to datajacks or other video links.

Rating	Effects	Essence Cost	Cost	Legality	Street Ind.	Availability
1	Stable Signal	0.1	5500¥	Legal	1.0	3/24 Hrs
2	Simple Shifts	0.15	10500¥	Legal	1.0	3/24 Hrs
3	Complex Presets	0.2	17500¥	6P-CA	2.0	9/14 Days
4	Dynamic Response	0.25	28000¥	4-CC	3.0	18/1 month

Biopower Implants [Class: Cyberware (Body)]

Bio-energy! Not only the bodies metabolism, but constant internal and external motion generates power 24/7... mostly to bleed away unused. No longer! Biopower implants are a unique blend of bioware and cyberware. Using the same piezoelectric systems that power cyberware, the Biopower implant stores that power, rather than using it. Developed initially to combat the fatigue associated with extensive use of the PMP Musculature Lacing System, these units can power other cyberware, or even cyber-implanted equipment. Alternatively, the special chemical power-storage can be released back into the body to sharply increase the body's metabolism of waste products and fatigue poisons (1 "charge" can be used as 1 die in Stun-recovery tests, 2 equal a taser-equivalent charge, and 3 an electrical power supply equal to a single "gelpack" battery) Charging rates and maximum capacity are below -- note that each listed is a system, and cannot be doubled up any more than buying wired reflexes twice would equal Wired Reflexes rating 2. Note that while biopower implants are "equivalent" to a gel-pack's power output, a special converter is needed to actually USE the power as such. Finally, note that due to the nature of the power generation, the system cannot collect power during any hour where a stun-recovery was taken.

Rating	Effects	Ess.	Cost	Legality	Street Ind.	Availability
1	Body/10 per Hr, max=Body/2	1	25000¥	Legal	1.5	6/2 days
2	Body/7 per Hr, max=Body	2	60000¥	Legal	1.75	8/4 Days
3	Body/5 per Hr max=Body*1.5	3	125000¥	6P-CA	2.0	12/16 Days

Ruthenium Ocular Mods

[Class: Cyberware (Cranial)]

Tired of looking out at the world with the same old eyes? Rating 1 mods give clear, crisp color, controllable via data-jack, wireless controller, or ChromaSync SPU (vivid color, looks fake :-)

Rating 2 mods go deep into the eye itself, allowing great color retention and replication — look as natural or UNnatural as you want. (Rating 3 mods are beaucoup illegal, chummer -- rumour has it they dig the ruthenium into the retina. Very tricky, but real handy when you don't want surgery every time you change your ID... even if you aren't changing it to someone else's)

Rating	Effects	Essence	Cost	Legality	Street Ind.	Availability
1	Obvious pattern change	0.1	2000¥	Legal	0.75	3/24 Hours
2	Natural looking changes	0.1	5000¥	Legal	1.0	4/36 Hours
3	Retinal Pattern change	0.2	150000¥	2-CC	2.0	14/21 Days

Ruthenalin Implants

[Class: Cyberware (Body)]

Utilizing a process similar to ortho-skin implantation (but without the thickening and loss of sensation orthoskin causes), this process replaces the skins natural melanin production with neurolinked ruthenium/bacteriorhodopsin analogs, allowing virtually instantaneous skin-color changes in many patterns, depending on the sophistication of the substructure. Rating 1 and 2 systems do NOT access the central nervous system of the user, and thus can only be altered by passing a reprogrammer (available in many styles and sizes for your convenience) over the effected portion of the body. Note that rating 3 and 4 systems require a ChromaSync SPU linked to the system in order to interface with the users nervous system. If installed simultaneously with and orthoskin graft, all Essence costs for the Ruthenalin implants is halved, but the cost of the Orthoskin itself is raised by an /additional/ cost equal to the the cost of the Ruthenalin implants.

Rating	Effects	Essence	Cost	Legality	Street Ind.	Availability
1	Partial Coverage	0.2	5000	Legal	0.75	2/24 Hrs
2	Single static pattern	0.5	15000	Legal	1.0	3/48 Hrs
3	Instant pattern change	1	45000	8P-CA	1.25	4/3 Days
4	Dynamic pattern change	1.5	80000	4-CC	2.0	18/1 Month

☛ Heya.. gotta ask for a bit of help here. One of my chums drew this under hypnosis.. She says she saw something similar to this while on an astral quest. She's studied and she thinks it's some sort of metaplaner critter. Could anyone expand on this?

☛ NuDawn

☛ It's a nasty metaplaner critter?

☛ Wize

☛ Ah yes. I know what it happens to be, but I'm afraid I can't tell you over an open channel..

☛ Trent



- ◆ Hey folks, someone snagged this off of some Ares public datastore and sent it my way. Looks like it may be of some interest to you guys and gals, so here it is.
- ◆ NuDawn

Ares Light Rope 2100

The Ares Light Rope 2100 is a huge improvement over a great product of the late 20th century. Flexible like a garden hose, but filled with near-unbreakable high-concentration lights, the ALR 2100 is the most versatile and reliable of similar equipment on the market today!

Originally used as fire fighting equipment, this style of lights has many other practical applications in the corporate world. Short strips can be used to mark locations at night, or during foggy days. With the new Colourstrip, you can pre-order your colourstrip to come in a single fixed colour on the RGB scale. With the Enhanced Colourstrip and Ares Colourstrip Coordinator, you can instantly change to any colour on the RGB scale! Helicopter landing lights, traffic direction arrows, these ropes can do almost anything!

Guaranteed for 5000 hours of operation, ALR 2100 is resistant to water, acid, fire, and will not snap under pressure! (Wish we could make all our corp-execs like that, ha ha :-)) In the unlikely event that one of the bulbs breaks, the rest of them keep on ticking!

ALR 2100 can run using a dual plug system; taking up both plugs on a standard outlet, one industrial sized outlet, or via an Ares Battery Pack (12 hours of operation).

Ares Light Rope 2100 is shipped in 10 meter increments. Please call for discount pricing on large orders. We guarantee two-day delivery to anywhere in the CAS, UCAS, and most of North America!

Pricing:

Regular	20¥ / 10 metres
Colourstrip	30¥ / 10 metres
Enhanced Colourstrip	40¥ / 10 metres

Ares Colourstrip Coordinator:

Conceal	Weight	Availability	Cost	Street Index
4	1	Legal	300¥	1

- ◆ This is exactly the kind of stuff for all of you reprobates out there with the burning desire to write obscenities on city buildings in big, twenty foot high letters of flashing neon.
- ◆ Flayre
- ◆ And it can be used to send messages quickly, if you don't mind being spotted. Lay out the line in the shape of the letters you want and switch it on.
- ◆ Booter
- ◆ Another creative use: it's damn bright, so a quick flash from up close can cloud a persons vision. Of course, most corp-sec types have either sunglasses or flare comp, but it's worth a try.
- ◆ Alter

◆ Some businesses use it in place of traditional neon signs. This lighttrope is much less prone to breakage (like when some gangpunk throws a brick at your sign) and it can be formed into the same shapes. Plus it's cheaper.

◆ Steve

◆ Here's a few new things that have recently hit the streets. The original designs of these nasty little things is from Yamatetsu, of all places, though you won't find them in any catalog. Enjoy, and drop me a line at LTG 286-680601 if you see anything you like.

◆ Lifeline

Cyberware

Retractable Fangs

Retractable fangs are cybernetic implants within the mouth that replaces the upper first canine teeth with stainless steel teeth capable of extending out to one inch in length, and retracting back to normal length. These false teeth can also be enameled to match your other teeth.

These teeth have become quite popular among the gothic community as they allow a person to gain a "vampire" look.

◆ Hehe... Who needs fake fangs when I got real ones?

◆ Alucard

Retractable Fangs can also have a venom sac added, allowing the bearer to give a "poisonous" bite.

◆ Adds a whole new level to the phrase "Bite Me". :)

◆ Plisken

Essence Cost	Cost	Street Ind.	Availability
0.1	5,000 ¥	2	4/7 days

Venom Sack

The venom sack is a small fluid compartment placed inside the upper jaw, allowing the user to secrete a poison through a set of hollow steel fangs. The sack holds enough venom for up to 20 injections, and can be refilled with minor work. Various poisons and knock out poisons are available.

Essence Cost	Cost	Street Ind.	Availability
0.1	8,000 ¥	3	8/14 days

◆ Be VERY careful with these, especially if you pick up the Deadly Venom. One good shot to the head in the right place will crack the sack, and leak poison into your blood stream. A guy I ran with on occasion had a venom sack. He got into a bar fight, took a shot to the head, and went unconscious. 2 minutes later, his face is turning black and he's convulsing. Not a pretty sight.

◆ Sin-sin

◆ Another thing to worry about is that these things are a pain to refill. I got me a set of the fangs, and ran out of venom a while back. Went in for the "minor work" of having the refilled. The doc had to pull the sack out completely to refill it. Was just as much work to have it refilled as it was to have it put in the first time. More trouble than it's worth. I wish the bioware version of the venom sack was compatible with the retractable fangs. Would make life a whole lot simpler.

◆ Troglobite

Bioware

Venomous Fangs

These bio-engineered poisonous fangs are designed similar to a cobra's. A Poison Gland is implanted, along with a venom sack and a set of 1/2 inch fangs. This gland secretes enough for 6 bits at one time, and refills itself every 12 hours.

Two types of venom are available, lethal poison and a non-lethal knock out poison. The lethal deals 8D damage, while the non-lethal deals 8D stun. It is not possible to get both lethal and non-lethal put in.

The venom gland is not compatible with the retractable fangs cybernetic implant.

Body Index	Cost	Street Ind.	Availability
0.5	Non-lethal: 15,000 ¥	2	4/7 days
	Lethal: 18,000¥		

◆ These are beautiful. Be real careful of biting your own tongue though. This can hurt. A lot. I suggest getting a toxin filter installed with this to keep yourself out of trouble.

◆ TheC@In.The.Hat.Net

◆ Take care to whom you show your fangs, some people can get just a little to nervous if they see them. To parade as a vampire is not always a good thing to do.

◆ Barbie

◆ What's even worse are the vampire wannabe's who chase after you screaming, "Bite me, bite me!"

◆ Graht

Nova Infranational

◆ Who are these guys you ask, well they replaced our old friends Nostalgia Industries, it seems that Nostalgia lost they're market share in a failed attempt to revolutionize the market of melee weapons, along with the fact that they only barely survived in the first place, well needless to say Nova Infranational, a relatively new company with 'Innovative and Impressive ideas' or at least that's what their first brochure said, needless to say, when they bought up Nostalgia's market share, or what was left of it, they also picked up the NI initials, and asked me for a post, so everyone give it a once over, and see if you think I should keep them on until next time.

◆ NuDawn

OneShot

Everyone needs a lighter, whether its to light your smokes, help you find your keys in the dark, or save you with a 8mm round through an assailant. With your average lighter the latter is not very possible, but with the Oneshot from Nova Inf. you have that one chance many of you have wished of

at one time or another, not only is the Oneshot perfect for that impromptu distraction it comes in a variety of colors and designs, just note your preference when ordering.

Type	Conceal	Ammo	Mode	Damage	Weight	Availability	Cost	Street Index
Holdout	9/14	1	SS	5M	.25	10/7 days	80¥	1.5

Telcom Taser

Operating as a normal Handheld Telcom unit, the T-Taser has one unique function that gives you the ability to quite literally 'reach out and touch someone.' The T-Taser works as a fully functional handheld telecom, and the taser works by pressing the # and * key at the same time. This causes the dual antennae to shoot out tasers, they have the same affect as a standard taser, but at half the range. The T-Taser comes in an assortment of colors and styles, when ordering just be sure to state the color and model you wish to purchase.

Colors and Body styles			
Color	Color Code	Style	Style Code
Beige	11-010-01	Palmsize	11-012-01
Charcoal Grey	11-010-02	Ergo Palmsize	11-012-02
Ebony	11-010-03	Standard	11-012-03
Dayglow Orange	11-010-04	Ergo Standard	11-012-04
Crimson	11-010-05	Molded	11-012-05

Type	Conceal	Ammo	Mode	Damage	Weight	Availability	Cost	Street Index
Taser	8/12	1	SS	6S	.75	12/7 days	750¥	2.5

Sample Collectors

Ring mounted sample collector

For use when you need to get the sample without holding a scalpel in your hand, the ring mounting is concealed in a decorative face. With a simple twist you can produced the circular blade that takes tissue samples from the palm of the hand, or the shoulder. Whichever way you prefer.

Sample Collection Kit

Everything you need to take samples of paranormal animals or anything else of the like. Included in this is a pen with a collector rod in the rear. It looks like a fully functional fountain pen, until you twist off the back to expose the reinforced collector.

Sample Storage Unit

Without the storage unit, the samples go bad within a day or so, but with the storage unit you may hold them indefinitely, just like the corps do when they catch you doing something they don't want you to, and keep your sample on record.

Pricing: Designer Ring: 275¥
 Generic Ring: 70¥
 Kit 480¥
 Storage Unit 11,175¥

SwiftOne Speaks

by SwiftOne <swiftone@bigfoot.com>

Covered this Month: Rigger 2 (sourcebook), Headhunters (novel), Clockwork Asylum(novel), SRTCG (trading card game), SRCARD (mailing list)

Welcome to my new column! **SwiftOne Speaks** should become a regular feature of The Shadowrun Supplemental, offering reviews of recent sourcebooks, novels, and other Shadowrun developments.

I'll take this opportunity to attempt to impress you all with my qualifications. I've been playing Shadowrun since 1st edition was released in 1989, I own almost every sourcebook ever printed for it (with the notable lack of adventure modules), and have followed the novels religiously. 'Nuff said.

- ◆ In other word, I 'hired' the best :)
- ◆ Adam

My reviews will try to cover the points of a work that are of interest to players and GMs, while not revealing any surprises. I'll also offer a summary and a rating on a 10 point scale of everything I review. I tend to be a cynic, so don't expect to see many 10's. On the other hand, any 10's you see must deserve it.

My 10 Point Scale

- 0 = I pity the tree that died for this
- 1 = Ignorance is bliss
- 3 = Pretty Bad
- 5 = Borrow someone else's
- 7 = A good read
- 9 = Practically Mandatory for all good SR players
- 10 = Gibson and Tolkien in one

I will gladly accept any feedback from the readers. The email address swiftone@bigfoot.com should be good for several years. If not, simply search for SwiftOne. Please, however, make sure I can understand that you are writing regarding my **SwiftOne Speaks** column. I get lots of other mail and I might not realize what you are referring to.

I'm interested in hearing if anyone is interested in me running a summary of previous SR novels, giving only the Rating, pros, and cons of each. Email me with your vote and I'll respond in turn.

These mundane details completed, lets get on with the reviews

Rigger 2**Sourcebook****Author:** Jonathan Szeto**Rating:** 8**Pros:** Rules given for most aspects of a rigger's life, including vehicle maintenance, combat, drones, vehicle creation/modification, and security riggers. New vehicles and a few nice bits of cyber are included as well.**Cons:** Rules are given...a lot of rules. Some of the new combat rules will take a long time to get used to. No useful table of combat rules in the back.

Rigger 2, one of the most anticipated and requested books since VR 2.0. Not surprisingly, the two books have quite a bit in common. Like VR2.0, Rigger 2 makes a formerly difficult type of character a real possibility to play. The vague areas of vehicular combat and usage are cleared up, drones are explained with more detail, and many new vehicles and toys are introduced, including a reasonable set of vehicle creation/modification rules. This is a book long overdue.

However, like VR2.0, anyone wanting to use the rules will have to read the book a few times and take careful notes. Vehicle combat is now possible, but involves many tests and chart-based modifiers. Until you are used to it, expect to be thumbing through Rigger 2 quite a bit when you try and use it.

The book itself is laid out in a more consistent manner than VR2.0, but still suffers from the "information overload" effect that book had. The only real way to handle these rules is to try them. Again and again. After 5 combats, you'll have the basics down pat. Players being players, however, you can expect that this will become a frequently consulted book to decide on particularly curious rulings. ("Okay, so if the dwarf gets wrapped around my axle, what does that do to my cruising speed?")

The book also offers a whole bunch of new toys and goodies in addition to clarifying old rules. The new vehicles are decent, nothing too overwhelming. Some of the new drones offer interesting possibilities. The vehicle creation rules are acceptable, but a wise GM wouldn't let a player number-crunch too long...the rules were created as a guide, not as a guaranteed flawless method. Other toys, such as the BattleTac for vehicles, offers plenty of reasonable abuse potential for both GM and character alike. Of course, the favorite device of riggers everywhere is the new Cranial Remote Control Deck.

While some modifications were great things, (such as upping the cost of a Windjiina) others I'm not so sure about. Introducing robots, as very fast, very strong machines doesn't really fit in with the SR universe. (my principal question would be: "Why develop robots, when drones/vehicles could do any job better?") Other tricks, such as allowing a rigger to take over a rigged security system, threaten to destroy "standard" security setups for many a GM. The book also suffers from many long-standing FASA errors, such as examples that contradict rules, a lack of Street Index and Availability listings, and other such editing errors. I didn't notice any references to page xx however. A new editing formatting annoyance popped up: In an attempt to break away from the one vehicle/gear per page format, they push several items onto each page. Unfortunately, the resulted in headings on some pages for the items on the following page, pictures next to the wrong items, and a generally hard-to-read format. I guess we're never happy.

Overall, this is a long overdue book and Mr. Szeto has done a wonderful job of filling this gap. As with VR2.0, this will become part of the "core" collection. Non-riggers or anyone for whom vehicle combat is happily abstract will have little use for most of this book, however.

The basic rules from Rigger 2 will be included in SR 3rd edition, and the advanced rules are not expected to become outdated. If you or your group has a decent amount of vehicle interaction, this book is worth the investment.

Headhunters

Novel

Author: Mel Odom

Rating: 6

Pros: Good character development, great attention to detail. Focuses on the shadowrunner outside the run.

Cons: More appealing to the emotions than by action. Some nasty blatant disregard for some SR rules of reality. Some of the moon-eyed actions of certain characters can induce nausea if you aren't inclined to that sort of thing.

The continuing adventures of Jack Skater and his team (of Preying for Keeps fame), this time with his infant daughter in tow. While he learns to adjust to the pressures and responsibilities of fatherhood, his team gets caught up in a vile plot of which they have very little understanding. (don'tcha hate it when that happens?)

Without revealing the plotline too much, Jack and his team are on the run with a very popular corpse...and they have to figure out WHY it is popular and what to do about it while they are still alive to have a choice. All this happens while Jack is having an identity clash between his runner half and his paternal half, not to mention a conflict that he doesn't understand (although everyone else, including the reader, does from page 5 on) with Archangel.

Odom shows his strengths once again in the captivating characters of Elvis the troll and Duran the ork, making heroic stereotypes seem fresh, round, and interesting. His attention to detail is doubtless what does this...small little notes he makes about things that lend them a believability that many authors should strive for.

While some of his characters are wonderful, the novel is not perfect. Many, perhaps too many, SR realities get tossed out the window in the name of artistic license. Also, as the novel focuses on Jack's emotional battle(s), and the group is on the run, anyone looking for a good action novel will spend most of the time disappointed. There is also an attempt to tie in the running "Who killed Dunklezahn" plot which seems a little weak and contrived.

Overall, Headhunters is a good novel, and worth a look. Anyone interested in developing a characters personality beyond the facts of a run might find this a useful source to begin with.

Clockwork Asylum**Novel****Author:** Jak Koke**Rating:** 7**Pros:** Vast character development beyond Stranger Souls. The Dunkelzahn plot thickens.**Cons:** I'm a little tired of Dunkelzahn myself, and Mr. Koke has a large number of high powered characters running around.

In this sequel to Stranger Souls, we return to Ryan Mercury, as he struggles to understand his loyalties, recover the Dragon's Heart, and locate Dunkelzahn's killer. Also included are Burnout, Lethe, another expendable mage, the Incorporated Assets team, and the pneumatic Nadja Daviar.

Mr. Koke really out does himself when it comes to character development. The rather potent characters introduced in Stranger Souls take a step back from their considerable powers to answer to the realities of their emotions. Mr. Koke manages to do this well, without the constant pathetic whining that is the result of failed attempts at character development. The characters deal with a variety of emotions, and become full, round characters. Heck, even Burnout the cyberzombie shows some human traits.

The novel does have its weak points. I tend to dislike overly powerful characters, which abound in this tale, and which the hero is in particular. The novel also pays more attention to the workings of these high individuals rather than the street-level shadowrunning that most of us are interested in. The plot was also weakened by characters stepping in saying "aha, this is the answer! Here is all the proof you need" rather than having the facts slowly present themselves. For a book that in a large way revolves around a mystery, there was very little mystery.

Still, the novel was a great read, and the characters were very well developed. Mr. Koke has succeeded in making a sequel that is better than the original. In particular, if you are following the growth of the SR universe, I suggest you pick this one up and read it before the next novel in the Dragon Heart trilogy, Beyond the Pale, reveals the answers to some long burning questions and changes the game world.

Shadowrun Trading Card Game (SRTCG)**Trading Card Game****Author/Creator:** Mike "Skuzzy" Neilson et al**Rating:** 8**Pros:** Very good game, well thought out. Designed to avoid many of the traps that M:TG has fallen into. Much better balanced than other CCG attempts.**Cons:** Many "alpha" type bugs. Amount of future development still unknown. Art is less than great, and flavor text is pretty boring.

It's inevitable that every time a new CCG comes out, it gets compared to Magic: The Gathering. In this case, however, it is a comparison that was expected and prepared for. FASA has designed a game specifically to occupy the niche that Magic does not: ease of rules. Ads have been printed targeting players who would play Magic, except they have not received the hourly update of the errata and timing rules. The game seems to deliberately attempt to correct errors and flaws in other popular CCG's.

Does FASA measure up? Does SRTCG offer something that Magic and its many clones and knock-offs can't? I'll say yes.

First, the basics. The game is designed for 2 or more players, with multi-player games functioning fairly well, but 2 player seems to be the most popular. Each player lays out Objectives, which any player can then try to accomplish. Each player builds teams of runners and their gear to attempt to accomplish the Objectives. Each Objective has a certain number of Reputation points, and the players go towards a previously established amount of Reputation. Each player lays Challenges on any Objective in play that others must defeat before they can accomplish the Objective.

Does it work? Yes. The gameplay is well-explained in the rulebook, and is very easy to pick up. The different cards offer a large amount of variability, so that a deck is not a predictable thing. Starter decks are supposed to come with a pre-set arrangement that will allow even one starter deck to be playable. [There was a large number of complaints of poor separation/distribution in the first printing. FASA has reportedly dealt with the error with the company that actually prints and sorts the cards for the second printing.]

Did they accomplish what they sought? Mostly. Timing issues have indeed been greatly simplified by application of an "instantaneous" rule. That is, a card played takes effect instantly, without time for another card to be played to effect it, with a very limited number of obvious exceptions. The only trouble is convincing the players of this. Most experienced players are not used to such a concept, and have troubles understanding the timing rules for the first few games. After some trial, effort, and a few clarifications from the FAQ on FASA's web page, the rules are obvious and fairly easy.

Overall, I find the game fun, and much better balanced and thought out than most CCG's coming to market. The disadvantages are mainly in the resemblance to the Alpha edition of Magic...many terms need strict definition, and timing issues need to be clarified. The second run printing should fix many of these, and future expansions should clear them all up. FASA has really done their best to avoid getting into a constantly growing vortex of rules and clarifications and errata. An expansion set, The Underworld, is already planned, and some areas, such as physical adepts have not yet shown their face.

The game does have weaknesses. The art is typical FASA fare...some good, mostly bad. The flavor text is almost always boring and dull. (With some hilarious exceptions).

Now the basic question that you all are left with I have not yet answered: How good a translation is it? The answer: Decent. I would say that the flavor is the same, while details differ (Such as a Stim Patch healing Physical damage). The flavor is close enough that I've heard of GMs grabbing a few Challenges and Objectives and using them to create instant runs. I don't think any SR players will get disgusted by playing this game.

SRCard**Mailing List**

List Fearless Leader: Loki

Rating: 8

Pros: Great place to get clarifications on commonly asked questions and issues with SRTCG. Very little traffic for a mailing list.

Cons: Not trafficked by any official FASA reps. Not as helpful once you understand the basic rules.

SRCARD was created only days after SRTCG was released. Loki, the head honcho, and several others led the way in trying to get a complete set, and testing the game out as well. Early timing issues and poor card texts were first discovered and corrected here.

I joined the list only a few days after it was first started, and quickly found answers to my SRTCG questions. While not trafficked by any official FASA reps, they quickly recognized Loki and the SRCARD list as a place where their answers (semi-official, only answers appearing in the FAQ on the FASA web page are considered official) could get distributed, and respond to questions he forwards rather quickly.

I really found the list an invaluable tool. While the SRTCG rulebook was well-written, sometimes you need things explained out in lengthy detail. The list was someplace where I could get those answers. I also was kept informed of the raging timing debates, whereas if I had played the game without the lists, who knows how ignorant I would have been. Trade lists are occasionally posted, but more often are kept on Web pages with links in email messages, so the group is not overwhelmed with trade requests and replies.

Since those first few days, I've remained subscribed to the list, but found very little use for it. New people join in and ask many of the same questions I did, but there are already a lot of people to answer before I even get their messages. Traffic is fairly low (for me, that is. It gets about 20-50 messages a day) so I've stayed subscribed. I fully expect that I'll be needing and enjoying the list again as soon as the expansion set comes out.

Details concerning list etiquette [Etiquette (Mailing List)?] and subscription information can be found at the SRCARD FAQ at: <http://www.primenet.com/~gamemstr/srstuff/tcgfaq1.htm> and <http://www.coastnet.com/~dvixen/srtcg/tcgfaq1.html>

Target: Jak Koke

Interviewer: Bull <chaos@ncweb.com>

Jak Koke is a freelance novelist and short story writer. His works for FASA include Dead Air and Stranger Souls. His current Shadowrun novel is Clockwork Asylum

First, the important question. How did you get involved with FASA?

This is a long story, though I'll try to make it relatively short.

A few years back, I wrote part of a supplement for Steve Jackson Games — an adventure called "Jericho Blackout" in GURPS: Cyberpunk Adventures. There's a whole sordid story behind the writing of that as well, but I won't go into it now.

I was writing a lot of short stories at the time, and had sold one or two to genre magazines. "Jericho Blackout" was based on a short story that Jonathan Bond and I co-authored. When the supplement was published I showed it off at my writer's workshop — The Pulphouse Gang group in Eugene Oregon. We had a lot of publishing writers: Dean Smith, Kris Rusch, Nina Hoffman, Jerry Oltion, and others.

After the workshop, this guy comes up to me. I didn't know him, really, except his name was Greg and he drove down from Portland every other week for the workshop. He introduced himself and said that he hadn't known that I did game supplements. He said that he was a game designer and that he was currently designing a fantasy role-playing game.

We talked about role-playing and fiction writing and generally hit it off.

A month or two went by before anything else of significance happened. I kept writing short stories and kept sending them out. It's a tough lot, trying to break into the fiction writing business. I made a few sales and had a lot of rejections. I have over three hundred now.

Anyhow, back to the story... Writer's workshop a month later, Greg announces that he is working for a game company, designing this very cool fantasy game, and that the company needs good writers to submit novel proposals. Talk to him after the workshop if interested.

He was mobbed.

I got the guidelines from him. All proposals were to go through him, the company was FASA, the universes were Battletech and Shadowrun. The FRP he was designing was Earthdawn, but FASA didn't want any proposals for Earthdawn novels at that time.

I started thinking about ideas for novels.

Two weeks later, Greg talks to me after the workshop. FASA has a problem. They have to produce five Earthdawn novels to give to Roc. Chris Kubasik is writing the first three, Greg is cranking out the fourth, and the fifth is a braided anthology featuring six stories. They only have five writers: Lou Proserpi, Tom Dowd, Chris Kubasik, Scott Jenkins, and my friend, Greg Gorden. They need a sixth writer -- someone who can learn the rules of the Earthdawn universe quickly and submit a proposal for the story. Would I be interested?

Don't have to ask me twice. I wrote the proposal for what became "Coiled in Dark Amber" — my story in the TALISMAN anthology. Sam Lewis who was then president of FASA, liked the proposal. He sent me a contract and I wrote the story. It was published in Earthdawn: TALISMAN in 1994.

That's how I first wrote for FASA, but the story doesn't really end there. After they bought "Coiled in Dark Amber," I submitted seven (count them) SEVEN novel proposals — four Shadowrun and three Earthdawn — before I got a response on one.

Donna Ippolito, the editor of the novels, contacted me and asked me to write a detailed outline and several chapters based on the proposal I sent in for LIFEROCK, an Earthdawn novel which chronicles the story of a young obsidimen and his quest to save his liferock (and his entire Brotherhood) from annihilation.

I wrote these chapters and the outline, and made the sale. The book is written now, awaiting publication. It's really a very cool book. I'll talk more on it later.

After LIFEROCK, I switched to Shadowrun exclusively, mainly because FASA quit buying Earthdawn novels. I wanted to write a Shadowrun book anyway, but I still liked the Earthdawn universe. Still do.

I came up with the plot for DEAD AIR based on a short story that Jonathan Bond and I wrote in collaboration. You can read the original short story from my web page (<http://ursula.uoregon.edu/~jkoke/>). Jonathan and I have written over forty stories and about one and half novels together.

Anyhow, Donna liked DEAD AIR and took me seriously when I suggested writing a trilogy about some "big events" that would give movement to the Shadowrun universe. She passed my desire to participate in these sorts of discussions along to Mike Mulvihill, and he invited me out to Chicago for the series of meetings which spawned the ideas for the election, the assassination, etc. Steve Kenson and Paul Hume were the other non-FASA people at these meetings.

After that, I began to work on the "uber" plot of my trilogy and how it tied in with the other events. Mike Mulvihill and Steve Kenson and Jordan Weisman were all intricately involved in this plotting. Together we refined the entire sequence of events from SUPER TUESDAY through PORTFOLIO OF A DRAGON and ending with the last book of my trilogy, BEYOND THE PALE. Steve wrote the majority of the key game products while I worked on my novels. Mike, meanwhile, was busy coordinating and setting up clues to the big events.

All in all, a very exciting time to be associated with Shadowrun.

I hope that answers your question. <smile>

Tell us a little about yourself, if you would. Where do you live, how old you are, that sort of thing.

I am 33 years old. My name, while spelled Jak, is pronounced exactly like Jack. My parents decided that it would be cool to change the spelling because my initials are JAK. I think it's cool now, too, but when I was in grade school, I caught mega-doses of crap for it. Oh well...

I'm married to a wonderful woman who is a Ph.D. candidate at Scripps Institution of Oceanography in the Marine Biology department. She does research on a bacterial symbiont of a marine

invertebrate which produces a chemical called Bryostatins. Bryostatins has been effective against leukemia.

We have a four-year-old daughter, and we live in La Jolla. It sounds ritzy — La Jolla is the rich part of the San Diego area — but it's not. We live in married and graduate student housing. It's nice, but not fancy, and it's surrounded by condos, million-dollar mansions and streets filled with Lexuses (Lexi), BMWs and Mercedes.

We drive a Honda.

It is very nice here. Close to the beach, lots of sunshine, but not hot. Average temp is 70, and it's never been below 58 or above 88 in the nearly four years we've been here.

Eventually, we'd like to move back to the Pacific Northwest. We miss the mountains and the green and the forests and, yes, even the rain. The main thing we miss is the scarcity of population. It's hard to get away here, sandwiched between L.A. and Mexico with 8 million other people.

What else have you written that we should keep an eye out for?

My full bibliography is listed on my web page.

(<http://ursula.uoregon.edu/~jkoke/>) My novels are DEAD AIR, STRANGER SOULS, CLOCKWORK ASYLUM, BEYOND THE PALE, and LIFEROCK.

All of them are in print except for BEYOND THE PALE which is due in February or March of 1998 and LIFEROCK which is due at some unknown future date.

I've also had several short stories published, some written solo, some in collaboration with Jonathan Bond. My first sale was a cyberpunk novella called "Deadwise" — one of the collaborations. It ended up in *Amazing Stories* with full color art. Way cool for a short story. I've also sold horror and fantasy.

Almost none of my stories are available in print anymore, but I have put some of the up on my website. "Coiled in Dark Amber" can be found in Earthdawn: TALISMAN edited by Sam Lewis. It is still available through FASA, Amazon.com or any bookstore can order it. There is a horror piece called "Pieces of Prison" which was published in YOUNG BLOOD edited by Mike Baker that might be available. The others will be hard to find. Perhaps I'll eventually make it big enough to have them anthologized, but I'm not holding my breath.

I do have a current short story out in a great little 'zine called TALEBONES. The story is called "Cadillac Truth" and was just published. It was written as a tribute to the brilliant short fiction of Harlan Ellison. Visit <http://www.nventure.com/talebones/> for info and an excerpt.

What upcoming Shadowrun projects do you have coming up, besides the rest of the Dragonheart series?

Recently, I have shifted my attention away from Shadowrun to focus on trying to break into more mainstream science adventure fiction ala Michael Crichton. I suspect that the step into this arena is going to be as difficult if not more so than it was to sell my first novel. I have confidence in my writing ability, but there are many, many other good writers out there who are competing for a very few openings in popular mainstream fiction. My agent has advised me to keep my current projects a

secret for the time being, but if and when I finish them and they sell to a publisher, I'll let you all know.

What I can talk about is the Shadowrun novel that I am writing in collaboration with Jonathan Bond. The working title for this book is Edge of Fadeout and although we both like that title, it has almost nothing to do with the book so I'm sure it'll change before we're done. This novel is about vampires and magical genetic experimentation and organized crime and well, lots of drek. It has nothing to do with Ryan Mercury or the Dragon Heart Saga books, except that we've put in a cameo appearance by Nadja Daviar, and it has a very, very loose tie to Dunkelzahn's will.

I think people will like it. Jonathan is a really good writer and I'm glad to be working with him again. Look for more novels from him in the coming years.

Other than that, I don't have anything in the works. I did write more entries for "Threats" than made it into the THREATS sourcebook so perhaps FASA will publish those down the road.

Also, as I mentioned, FASA has yet to publish Liferock. They experienced trouble with their Earthdawn novel line a few years ago (after Talisman). Several Earthdawn novels have been commissioned, written, but not published.

Caroline Specter has two books, the first and second Aina books — Scars and Little Treasures. I have read these books and they are excellent. I have one novel, Liferock, and I think there are one or two others. It is a shame that these books remain unpublished because they are very good. I wrote Liferock in 1993. I have been paid for it, but no one has been able to read it. One of the main reasons that I write is to reach people, to entertain and occasionally to teach. I am very distressed that my book may never see print.

I'd really like to see the Earthdawn novel line start up again, and if enough people tell FASA that they'd like to see them, perhaps the books will eventually get published. Send email to FASAMktg@aol.com

What advice would you give someone who was interested in writing something for FASA?

First of all, go to my web page and look up the "7 steps to becoming a professional writer" They apply to all venues, not just FASA

As I mentioned above, the first novel I sold was LIFEROCK. I had already gotten an "in" with FASA via Greg Gorden, and still it took me seven proposals to get a good response. If I had stopped after 4 or 5, I would never have sold LIFEROCK, and never have moved on to DEAD AIR or any other books and we wouldn't be doing this interview.

My main advice is to write and keep writing. If you don't enjoy sitting down at the keyboard and creating story and characters, you'll hate being a writer. I know a lot of published writers who don't actually like to write; they like being published, but they don't enjoy the act of writing. My question to them is: why do you do it then?

So if you know you like to write, and you have the drive to keep doing it through rejection after rejection, then just keep doing it. Keep meeting editors, keep improving your craft, and eventually you'll get a break. That's just the way it happens. It is true that you can be a good writer and not get published, but the business of making a living as a writer is also about networking and finding an agent and a lot of things that aren't actually writing, but are more about business in general. I hope

I'm being clear. If you don't like to the non-writing parts, you won't like being a writer either. It's all part of the package, at least it has been for me.

Specifically, if you want to write for FASA. Get the guidelines and follow them. Send in proposals and more proposals. That's the basics. Now to give yourself an edge, go to a convention like GenCon and meet Mike Mulvihill and talk to him about your proposal ideas. Perhaps try to set up an appointment to talk to him. Be confident and act professionally. Novels are edited by Donna Ippolito and are much harder to get, but it can be done. Same tactics. Remember that there is a fine line between persistence and annoyance. Stay on the side of persistence!

Good luck.

Do you play Shadowrun?

This one is easy. I have played Shadowrun once. When first edition came out, a friend of mine GM'ed a single run. I enjoyed it, but he didn't like the game mechanics so we never played again.

My background in role-playing consists mostly of playing original Dungeons and Dragons and later AD&D. This was a long time ago when role-playing was in its infancy. I have also played GURPS and several custom games designed by friends, but I never again was part of a group which tried out Shadowrun.

Do you still play on a regular basis?

I only role-play about once or twice a year now at best. I just don't know anyone in this area who plays, and I don't really have time to search out a group anyhow. I find that when I'm writing books, I don't need the creative outlet that I use to get (long ago) from role-playing. So I suppose I don't really miss playing because novel writing serves the same purpose, I get to interact with my novel characters all the time.

I think I should use this opportunity to point out that I believe that role-playing did have a positive impact on developing my creativity. The act of creating a character and playing him or her taps into the same part of the brain that is involved in writing fiction. I believe that role-playing fostered my creativity and allowed me to develop some of the skills I now use as a writer.

With that said, however, I must hasten to add that I think it is rare that a role-playing session will make a good story. The fundamentals are different: In role-playing, characters are confronted with a situation and the outcome is uncertain, based on probabilities, luck of the rolls, and skill at role-playing. It is a game.

In fiction, characters are also confronted with a situation, but the author has spent myriad hours picking the exact nature of the situation and the characters such that he or she knows the outcome, which leads to the next situation, and the next, building and building to the climax of the novel where the character undergoes internal change or solves the mystery or whatever. The author knows the outcome of each situation that will arise, or he learns the outcome as it arises and discards those situations in which the outcome is not consistent with the desired movement of the story. Thus plot, theme and structure are developed and maintained throughout the narrative.

Some of these things can be present in role-playing, and often are, but rarely all of them.



What is your favorite type of character to write about?

So far, my favorite type of players to write about are physical adepts (thus Ryan) or riggers (Jonathan Winger), but I believe that any type of character can be fun as long as he or she is fully developed and fleshed out, then played out in a non-munchkinous way that is consistent with the internal motivation of the character.

The main character in Edge of Fadeout is an artist, a mundane really, though he has latent magical powers which he expresses through sculpture.

He happens to be the heir to a Mafia family's biz, but other than that, he's not special. Also featured is Martin DeVries, vampire who is also a vampire hunter. Not that I've ever played a vampire character, but he is a fun one

to write.

When Role-Playing, do you prefer being a GM or a Player?

When I role-play, which as I said is rare these days, I much prefer being a player. First of all, I don't have the time to create an entire campaign. Also, when I did GM in the past, I tended to ignore rules in favor of

cinematic storytelling. Sometimes it pissed off my players and sometimes they did things which didn't jive with the predetermined plot of the adventure. I know that that is the nature of role-playing, but as a GM, I wasn't very flexible or great at encounters that weren't predetermined.

I do however, like to develop cool interesting characters when I have the chance and play them in other people's campaigns. I like to focus on the adventure.

What is your opinion of Immortal Elves, Horrors, and all the really big, oddball stuff that has crept into SR over the years?

I know it is fashionable to hate Immortal Elves and Shadowrun/Earthdawn crossover stuff like Horrors in the Sixth world. I don't. I can see how Immortal Elves and Horrors can unbalance a game, but so can powerful NPCs like Great Dragons and unstoppable mega-corporate executives with thor-shots at their command.

I must admit that when I was first exposed to the concept of Shadowrun when first edition came out, my initial reaction was; how ludicrous! How can they expect anyone to believe that magic and dragons and elves can coexist with the Matrix and smartlinks and guns and drones? I didn't buy into it at all.

After I got over that, however, and I actually read the background material that discussed the Mayan calendar and tied the SR universe into an established historical context, I started to think; you

know, this is actually pretty cool. The background is consistent. Once you suspend your disbelief and buy into the cycles of magic (for which there is a historical/mythical precedent) then everything flows.

It works because the SR universe is internally consistent.

This consistency includes such untenable creatures as Immortal Elves, Great Dragons, The Enemy, and a previous high-level of magic (IE Earthdawn). Therefore I think these elements are appropriate for Shadowrun. However, I also believe that in many respects they have been over-emphasized in the fiction. Some novelists loved Immortal Elves, and they wrote solely about them. I believe that creatures of such power are part of the universe, but should not always take center stage.

Shadowrun should be primarily about shadowrunners, the little guys with exceptional skill and a lot of guts who move among giants (including IE, megacorps, dragons, etc...) and accomplish things they cannot.

What do you like to do to relax?

Hmm, let me see. I like to have fun with my daughter; she usually picks the game. I also play soccer or basketball, and I like to go camping, and have recently learned to scuba dive.

Of course I also do the typical things like watch TV, rent movies, drink good beer and read books (although reading seems to be less and less of a typical thing to do for most people). The shows I currently like on TV include but are not limited to Babylon5, Buffy the Vampire Slayer, Star Trek (both), Xena, and X-Files. Also recently, I've taken a liking to Earth: Final Conflict. It sounds like I watch a lot of TV, but I usually record the shows and watch them with the commercials edited out.

What was the last good movie you saw?

This is a tough one. I don't get to go to movies in the theater much, being a father and a pretty active guy, and I am very tolerant of those I do see in the theater. I loved Contact, for example, and Men in Black, though for obviously different reasons. I don't usually see a movie in the theater unless I'm going to have fun. Too expensive in both time and money. If the chances are low that I'll enjoy it, I wait until the video is released.

While I'm in the theater I try to let the movie carry me into its world. I know a lot of people who can't enjoy movies anymore; critics or wannabe critics who feel compelled to comment on everything; this scene sucked because Jodi Foster's lipstick was a different color than it should be, or whatever. I don't see the point; it just ruins an otherwise fun experience that I have already paid for. After the movie, days later, if it is appropriate, I dissect the elements of the story or the filming if I think I can use something for my writing, but I don't do it in the theater, unless the movie is just so horrid that I can't help it. But as I said, I have gotten pretty good at predicting which movies I'm going to like and stick to those.

I just recently got to see The English Patient on video and was impressed by its power. The filming was very good, but it was the story which brought tears to my eyes at the end.

I did see GI Jane in the theater and really liked it. It was much better than I expected, but I have never been disappointed by Ridley Scott. Demi Moore was excellent and the movie touched on the role of women in the military and gender roles in society as a whole. Perhaps not quite as good as Thelma and Louise or Bladerunner, but worth seeing.

What is one thing you would like to accomplish some day?

Career-wise, I'd like to get a book on the New York Time's Bestseller list, and I'd also like to have a movie made of one of my books. In my personal life, I'd like to have a positive impact on the world to make it better for my daughter and her generation. I am hoping I can do this through writing, but I am also supporting environmental organizations like the Planetary Coral Reef Foundation and the Institute of Ecotechnics in their efforts to develop and provide technology which can help society lessen its impact on the environment in which we must live.

What is one thing about you that we never needed to know?

Let me tell you a story. This one is true.

Multi-millionaire John E. DuPont shot my brother-in-law, Dave Schultz, to death. DuPont was not insane at the time. He was not delusional. As Dave was walking toward DuPont's car, coming over to say hello, DuPont raised his .45 and shot Dave in the chest. Dave fell to the ground, face down in the snow, crying out in pain.

Dave's wife, Nancy, was inside the house. She came to the door when she heard the scream. She watched as DuPont shot Dave two more times in the back as he lay in the snow. She started to run out to help Dave, but DuPont pointed the gun at her. Then, abruptly, DuPont drove off. He went back to his mansion and locked himself in. A stand-off with police ensued.

Nancy called 9-1-1 and ran to Dave. She held him for several minutes urging him to hold on, that the ambulance was coming. Dave was probably the strongest willed person I have ever known, and the most generous. He was a world-champion amateur wrestler (Amateur wrestling is an actual sport, unlike the freakshow that is professional wrestling. Amateur wrestling was in fact the first Olympic sport.) If anyone could have held on, Dave could have.

But DuPont had loaded his .45 with hollow point rounds. Rounds that tear up flesh instead of passing through. Rounds that are designed to kill. How could DuPont's intention have been something other than murder?

Dave died before the ambulance arrived.

A little over a year later, DuPont was convicted of third-degree murder. He was sentenced to between 13 and 30 years in prison. He should have gotten first-degree and life imprisonment, but his high-priced lawyers convinced the jury otherwise.

Nancy and Dave's two kids, my nephew and niece, will live the rest of their lives without Dave. I will live the rest of my life without him.

Perhaps you never needed to know this about me; it is not directly related to my Shadowrun work. But it is a significant aspect of my life; it has helped define who I am, and how I currently view the world.

I am cynical about justice. I am cynical about the media. Whose name do you know better in this whole affair; Dave Schultz or John DuPont? The victim is often forgotten as the media focuses it's sensationalist machinery on the killer, the psychopath or the rich defendant.

However, despite all my cynicism, I retain hope that positive change can happen. If Dave taught me anything from the way he lived his life, it was that the impossible can be accomplished through hard work, a continual quest to better yourself and an unquenchable love for others.

Thus, I try to use my writing and the rest of my life as an instrument to affect positive change in the world. I don't think I'm there yet; my Shadowrun novels are first attempts. But I do know that I'll continue to work at it until the day I die.

Thanks for the chance to discuss all these things with you.

QUICKSILVER LIGHTNING, Part 4

Steven "Bull" Ratkovich <chaos@ncweb.com>

Chapter 6

Sally stood up, stretching, testing out her suit of armor. In hopes of keeping her alive, and knowing that she was strong enough to run full tilt with even the weight of such massive gear, we'd outfitted the big Troll ganger with a full suit of Heavy Armor. Angel, on the other hand, stuck with a suit of light security armor, and both our new partners were outfitted with Ares Combat Guns.

"Won't we have probs with the Star, Bull?" Sally asked, hefting the Combat gun for emphasis. "I mean, this much heavy ordinance is bound to get noticed."

"I think we'll be ok for a little while Sally." I replied, pulling my own armor on and double checking my Deck. "The installation is outside the city, out near the Toxic Zone. The Star rarely goes out there. And I've got some Matrix pals running interference, so any calls to the Star should get slowed down some."

Ahh, the toxic zone. Such fun. Back a few dozen years ago, The cities of Cleveland, Ohio, and Erie, Pennsylvania got together and decided they needed a new Nuclear Power Plant. The old one, in Perry, really wasn't large enough to power both the city of Cleveland, a metropolis in it's own right, and the growing cities of Ashtabula, on the Ohio side of the border, and Erie, on Pennsylvania's side of the border. They were already close to growing together into a sprawl back then.

The job of building a new, and very large Nuke Plant was contracted out to the lowest bidder, of course, and that proved to be a major problem. The contractor decided to skim money off the project. Lots of money. And that meant that the building suffered in a lot of areas.

Three days after the plant went online full time, it suffered a major meltdown, the worst since the Chernoble Plant in Russia in the late 20th century, and irradiated the surrounding area. There is now a 25 square mile radius that used to be the city of Ashtabula that's now mostly an unlivable toxic hell-hole, and for miles around the TZ everyone refuses to live there except the dregs of society. It's mostly wilderness, so it's also a haven for criminals, shadowrunners, and others who'd like to be left alone, and with the land cheap as it is, there's more than one corp installation hidden out there, working on projects they don't want anyone to see.

Sally nodded, but still looked dubious. I smiled reassuringly and hefted a Panther Assault Cannon, after checking to see if my pair of Ruger Warhawks were secured to my waist. Her eyes goggled at the sight of the huge anti-tank weapon, but I ignored her and turned to Johnny.

"The van is fragged, dude. We're going to have to take the Landrover, and that things not armored or modded up at all." I told him.

Johnny 99 nodded. "That's ok. We shouldn't have any problems getting in, but on our way out we may run into problems. These are the Azzies, after all. You know how they get when you take their toys away."

I sighed and nodded back at him. "I know, Johnny. But Sorrento's got our number now, and he knows we're after him. And, he knows that I have data on Quicksilver Lightning. Until that info is

no longer worth anything, which will be anywhere from one to six months from now, he'll be on our asses. We have to get in there and get this info, and get it into someone else's hands, fast. That way, they'll have bigger fish to fry, and hopefully, we'll no longer be that big of a threat to them."

That was always a shadowrunners worst fear. That the corp would decide that THIS time, they were worth the effort of hunting down and killing. And if a corp decides to do you in, then you're done. No matter how good you are, there's no way you can survive for long against the kind of man-power and money they have to bring against you. With a half million nuyen bounty on your head, even your mother will turn your ass in.

"What's our time frame, Johnny?" I asked.

"45 minutes, Bull." He replied, looking at his watch. "We need to get going if we're gonna hit the place on schedule."

With a sigh, I motioned to Angel and Sally, then we loaded into a somewhat battered Landrover and headed off into the night.

Field Trip

Gurth <gurth@xs4all.nl>

This is an adventure intended as a relatively straightforward run for inexperienced players, though it could be used as in-between adventure in an ongoing campaign. It can be played using starting characters — the playtest group used standard archetypes — and the basics of the game can be explained to inexperienced players during the adventure. That doesn't mean it's a piece of cake, though...

Thanks & hello's go to Anja Berger, Meikel Dschey Janissen, Rainer Nagel, and the bearded dwarf lady Stefanie Pulla for “playtesting” this adventure (I made 99% of it up on the spot) at European GenCon 1997.

Finally, a spoiler warning: reading this article may spoil the fun if your gamemaster wants to use the adventure. Ask him or her if it's okay to read it; until then, **IF YOU'RE NOT A GAMEMASTER, STOP HERE, AS THIS ADVENTURE CONTINUES TO THE END OF THIS ISSUE.**

Background

In this adventure, the PCs get hired by Winternight, an organization out to destroy the world. Extensive information about the group appears on pages 23 through 30 of *Threats*, but that book is not necessary for this adventure unless the players want to investigate their employers; that possibility is not covered by this adventure (new players often don't think of this anyway, in my experience) so refer to *Threats* if they do. The adventure also includes insect spirits, for which reference should be made to the *Grimoire II* or *Bug City*.

Winternight has been stockpiling, among other things, nuclear weapons; a cell in the runners' city has the task of assembling enough information to build a reliable missile for delivery of such weapons. The cell has determined that it is lacking some information necessary to achieve this goal, most likely because it was lost in the Crash of '29. However, the cell does have a reasonable idea where to get it: if they can get to an old ICBM (intercontinental ballistic missile) silo, that was not connected to the computer networks of 30 years ago and still has its computers intact, they may be able to retrieve the data from there. They believe they've found one that is remote enough so that a) nobody important cares it's there, so the theft won't be discovered, and b) it's still intact. Trouble is, it's in Kazakhstan, built in the 2000s to house a PAN-27 *Demon* ICBM by the Kazakhstani government.

This is where the runners come in: the Winternight cell hires them to go to Kazakhstan, take out the computer core, and take it back with them. All in all this should be a fairly simple operation, were it not for the survivalists who've built an armed camp on top of the silo. They are basically afraid of the Awakened world in much the same way 1980s American survivalists feared the Russians, and for this reason they withdrew to a remote area to build a new community where magic would get no chance.

The Winternight cell knows about them, but reckons they are not all that much of a threat — they may be well-armed fanatics, but they have no one to fall back on or would even come to their aid. Unknown to Winternight, though, the survivalist group have been gradually overtaken by insect shamans and spirits, who saw the survivalists as an ideal starting point for taking over the surrounding area. The survivalist were made to believe that the best way to win once the magic-users would come, was to ally themselves with the insect shamans. Since the survivalists had no magicians

of their own, this was a relatively easy thing to achieve using mind control magics and carefully hiding all spirits except the perfect-meld flesh forms. The advantage for the insect shamans and spirits is that the survivalists provide excellent protection for the hive, and the survivalists' strong will allows the creation of more human-looking spirits than otherwise possible.

At the current time, several survivalists have undergone the summoning ritual that transformed them into insect spirits, though the majority are still human. The insect spirits have taken over the actual missile silo, extensively rebuilt the interior, and use it as their hive. They have absolutely no interest in the computer core, which is still present, even though getting at it may not be easy.

Getting Hired

The characters are contacted by a fixer about a job. Mr. Johnson wants to meet them in the back room of The Orange Oyster, a bar in the East Gate neighborhood of Bellevue. East Gate is a lower-class area, while the Bellevue district as a whole is much more high- and upper-class. The runners are to be at the bar at 15:00 hours and ask the bartender to use the back room. Mr. Johnson will meet them there.

The back room can only be accessed through a door behind the bar, and a door leading out into the alley behind the bar. The outside door is always locked, though, and cannot be opened from either side except with the key the bartender has in his possession. The back itself is about 3 by 4 meters and has once had its walls painted white; now, they're a dirty gray-brownish color with stains everywhere. The floor is tiled, and there is a single lightbulb in the center of the ceiling. Directly below it is a circular table with five kitchen chairs around it, and along one wall is an old sofa, big enough for three people.

No matter at what time the runners arrive, Mr. Johnson and her aide are already there. Mr. Johnson is an elven woman with long brown hair and wearing glasses, dressed in a conservative business suit. (This is armored, Ballistic/Impact ratings 3/1.) The man, also an elf, sits on one of the chairs and is using a laptop computer that's on the table. Its screen is facing away from the runners, so they can't see what's on it. If someone tried to look, the man folds the screen down and gives him or her an "It's none of your business what I'm doing on my computer"-look. The man doesn't say anything during the whole meeting.

The woman stands near the table, behind and to the side of the man. She does all the talking, occasionally giving a quick glance at the computer screen or looking at something on it for a few seconds. When game statistics are needed, use the Mr. Johnson contact (SRII p. 210) for both the man and the woman, but add Firearms: 3 skill and a Fichetti Security 500a in a concealable holster to each.

Once the team is assembled, the woman tells them that she represents a certain party which wants to hire the runners for a shadowrun that will take them to Europe for up to a week, depending on how quickly they execute the mission. Payment is 15,000¥ per runner, plus 15,000¥ for expenses. Of this money, they will get 5,000¥ each plus 5,000¥ for the team up front. (For example, with four runners the total payment will be $4 \times 15,000\text{¥} + 15,000\text{¥} = 75,000\text{¥}$, of which they'll get $4 \times 5,000\text{¥} + 5,000\text{¥} = 25,000\text{¥}$ up front. Try to avoid doing this calculation in front of the players — work it out beforehand and just let the woman say "We can pay you 75,000¥, of which 25,000¥ will be up front. The rest follows after successful completion of the mission.")

Should they want more money, they can negotiate about it; each side rolls a test pitting their Negotiation skill (which is 6 for Mr. Johnson) against the Willpower of the other (Mr. Johnson has

Willpower 5). If Mr. Johnson gets more successes, the price will stay at what she offered initially; if the players get more successes, perform the following calculation: subtract the players' asking price from what Mr. Johnson offered, and divide by the total number of successes the players got. Then multiply it by their net successes (i.e. their total number of successes minus Mr. Johnson's number of successes). Finally, add the result to Mr. Johnson's offer.

For example, Mr. Johnson offered 75,000¥ but the players want 100,000¥; they got 5 successes, Mr. Johnson got 3. The difference in prices is 25,000¥, which divided by 5 is 5,000¥. This is multiplied by 2 ($5 - 3$) to 10,000¥. That's then added to the base 75,000¥ to arrive at a total of 85,000¥.

If the players ask some outrageous sum (more than twice what Mr. Johnson offered), she will tell them "no" outright. Unless they're prepared to drop their price to acceptable standards, this job will pass them by.

If the players don't feel like doing this job at all, then it's too bad. Mr. Johnson will let them leave and contract the job to another group of shadowrunners who are willing to take it.

With the negotiations out of the way and the players agreeing to do the job, Mr. Johnson will give more details. She will tell them the run takes the characters to Kazakhstan, where they are to get into an old, pre-Awakening, ICBM silo that is unoccupied. Once inside, they are to remove out the computer core from the computer room and take it with them to Seattle. Once back in town, the core is to be placed in a locker in a bus station in downtown Seattle. The remainder of their payment will be in the locker.

Transport to Kazakhstan has been arranged: they will leave tonight at 20:00 hours from an address in Redmond. The runners must be there at that time with all the kit they intend to take along with them. If the players ask about it, she will mention that the runners will have to carry all equipment they bring along themselves.

At this point, Mr. Johnson tells the runners what she knows about the silo site: it is in a remote area of Kazakhstan, on a plain with woods close by. However, the silo isn't abandoned, as a bunch of survivalists has built a camp around it. The survivalists number around 200 men, women, and children, but not much else is known except that they're well-armed and willing to defend their terrain.

All the info that Mr. Johnson possesses (and wants to share with the runners) is on a datachip which she hands the runners. It includes a map of the general area and of the camp, the texts on the labels that are on the computer core (so the PCs will be able to recognize it), as well as the address in Redmond where the PCs are to be picked up tonight. She also gives them the key to the locker at the bus station.

Unless the players have any questions, this concludes the meeting. The runners can go off and do whatever they want until it's time to go to Redmond. This won't give them much time to buy equipment, though, so if that's what they want to do, keep Availability times in mind. Likewise keep an eye on the time when they're talking to contacts. Exactly what contacts may be able to tell them is up to the gamemaster, but it's not much. Winternight is a secretive organization, after all, and there isn't really anything that links this run to Winternight.

Taking The Plane

This bit is fairly straightforward, since it goes just as Mr. Johnson explained. At the address they've been given — which is an empty lot in a bad area of Redmond — they are picked up by a Hughes WK-2 Stallion helicopter (**Rigger Black Book** page 53) which lands a few minutes after they arrive.

The helicopter has no markings except for a registration number. Should the players want to check this out, it belongs to a private owner living in Bellevue; if questioned, he will deny any knowledge of Winternight (even though he is one of its Seattle members). It is unlikely players will want to investigate this far, but if they do just wing it, keeping in mind that the helicopter owner is a reasonably high-level corporate employee and is a member of Winternight — plenty of ways for him to make the PCs' lives difficult.

The side door opens and a man inside motions for them to climb in. Once the player characters are inside, the helicopter takes off and flies at very low altitude (about 25 meters, only pulling up for tall buildings) toward the east. After a while the border between the Seattle Metroplex and the Salish-Shidhe Council is crossed at high speed, and some 15 minutes later the helicopter touches down at the edge of a wide road at the edge of an open plain. About 100 meters away is a small jet transport aircraft with its rear ramp lowered and its engines running. The helicopter pilot tells the players to get on board the transport, and takes off again as soon as the PCs are out of the helicopter.

The aircraft, like the helicopter, has no markings except a registration number. It is registered to the same person as the chopper, should the players want to investigate when they get back home.

Inside the aircraft is a Polish jeep, secured to the tie-down points on the aircraft's floor so it won't move around inside the plane.

There are very simple (and uncomfortable) folding bench seats along the sidewalls of the cargo bay, and there is plenty of room for the runners and their equipment. The aircraft's crew consists of two riggers, one of whom is always jacked into the plane. The flight will take some 28 hours, during which time there will be very little to do for the PCs. If they want to sleep, they'll either have to sleep on the benches (which are uncomfortable and not very wide), the floor (hard and full of tie-down points), or rig up hammocks using the cargo nets on the walls (probably the best solution, if they think of it). The flight itself is uneventful, after which the plane lands on another road near a wood, this one in Kazakhstan.

The pilot and co-pilot help the PCs unload the jeep, and tell them the plane will wait here until the runners get back; however, they also mention that if someone should discover the aircraft, they will attempt to leave with the aircraft whether or not the runners have made it back yet. Unless something the runners do gives away the aircraft, though, nobody will come across it.

When the runners drive the jeep away, if they look back they'll see the aircraft crew remove camouflage netting from 200-liter fuel drums and start refueling the aircraft from the drums.

Polski-Fiat Jeep

This jeep is a very simple vehicle, open-topped and with seats for four people. It has rollbars with a searchlight mounted on the top, and the body of the jeep is very lightly armored. This armor only protects the passengers if shots strike the vehicle, though, and as there are no doors or roof it's easy enough for attackers to fire at the people in the jeep rather than at the jeep itself.

Handling	Speed	Body/Armor	Signature	Autopilots
4/3	30/90 (off-road speed: 20/60)	3/1	1	0

Using the jeep and the map that Mr. Johnson gave them, the players should have little trouble getting to the camp. From the landing strip to the edge of the wood nearest the camp is about 5 km, but there are no roads leading there directly, so if the players want to take this approach they'll have to walk through the woods for several kilometers. The jeep can be used to traverse the forest, but only at Cruising speed; faster movement will result in lots of rammed trees at the very least.

Whichever route the players decide to take, one or two encounters with paranormal critters can be used to build up some tension and make the runners expend some ammo and/or medkits.

The Camp

The camp is circular, with many little shacks built of wood, corrugated metal, and plastic sheeting; many tents of various shapes and sizes also appear in the camp; there is not a single multi-story building to be found anywhere. All of these buildings are used for housing and storage of food, water, weapons, and ammunition. More or less at the center of the camp is a larger building constructed of the same materials as the smaller ones, which is used as a communal hall, for meetings, councils of war, feasts, and so on. It is also used as the guards' barracks.

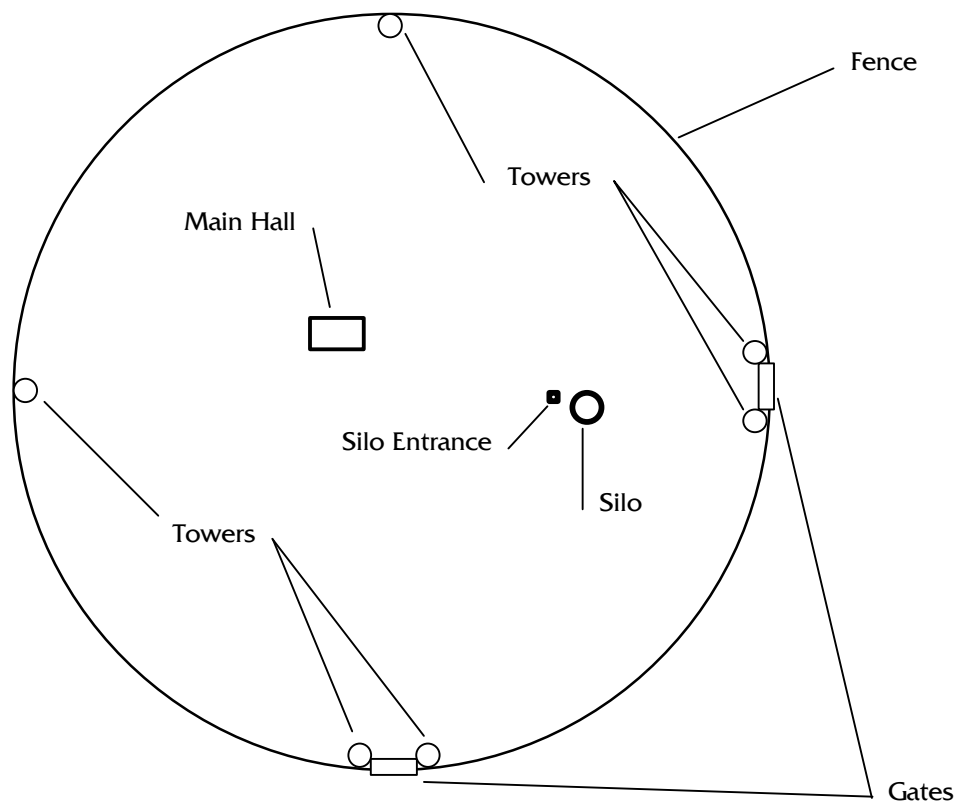

Security

The fence around the camp is about 5 meters tall, consisting of razor wire (see the *Corporate Security Handbook* page 99) nailed to wooden poles hammered into the ground every 5 meters. At the bottom is a roll of concertina wire, and another one has been fixed to the top of the fence. There are no high-tech sensors attached to the fence, so it is possible to cut the fence without any alarm going off.

There are six guard towers: two at each gate, plus one at the northern and one at the western side of the camp. The guard towers are about 7 meters tall (their floors are level with the top of the fence)

and made of wood, with wooden sides and a wooden roof. A ladder leads up to each tower from the ground. Anyone in the tower has partial cover (+4 target number modifier), and the wood at the sides and top of the towers has a Barrier Rating of 3. Note that the towers stand about a meter *inside* the fence, so the runners can't just climb up them.

There is a medium machine gun with 500 rounds explosive ammo pintle-mounted (this counts as a tripod) at one tower at each gate, as well as at the northern and western towers. These are mounted to fire the outside, so once the runners are inside they are safe from these weapons unless the guards remove them from the mountings. Each tower also has a powerful searchlight with a range of about 100 meters, but like the machineguns this cannot be turned to the inside of the camp.

The two gates in the fence are both made of wood and flanked by a guard tower on each side. One gate is at the southern side, and one at the eastern side of the fence. The gates swing open to the inside and can be barred from there as well. Their Barrier Rating is 12.

Around the camp, the grass has been cut short for about 10 meters, after that it grows almost a meter tall. However, tripflares are hidden in the long grass. These consist of a tripwire, about 3 meters long, attached to a flare. When someone pulls the tripwire, the flare goes up and the guards in the camp are alerted that someone is out there.

When the characters move through the grass, roll 1D6: a 1 indicates they may activate a tripwire if they're not careful. Let the players roll a Perception (10) test to spot the wire; success means they spotted the wire or the flare and can avoid it. If the Perception test is failed, roll two dice against a target number 4 if the characters are walking, or 2 if they are crawling; any successes means the flare is set off.

Guards

For the guards, use the stats below. One guard at each gate has an AK-98 instead of an AK-97, with 6 offensive minigrenades loaded into its grenade launcher. No spare grenades are carried, though.

B	Q	S	C	I	W	E	R	Armor
4	4	4	3	3	5	6	3	5/4

Initiative: 3+1D6

Threat/Professional Ratings: 3/3

Equipment: AK-97 [Assault Rifle, 38 (c), SA/BF/FA, 8M, 3 clips Regular ammo), Camouflage Clothing (0/0), Helmet (+1/+1), Knife [4L], Vest with Plates (4/3)

Remember that these survivalists fear anything to do with the Awakened world, meaning they have no magicians and will concentrate their attacks on anyone displaying magical abilities. Note that they do recognize magic when they see it (make a Perception test as per Noticing Spellcasting, SRII page 132) seeing how they do have to know what to fight, after all. However, this is also one of their weak points as no magicians means no spell defense.

There is one guard in each tower, plus two additional guards at each gate. Furthermore, there are 10 more guards on call in the main hall. If a fight breaks out, these guards come rushing out and can be there in about 2 minutes, less if the fight is close to the hall. Two of these guards walk around the fence (on the inside) every hour, starting at the western gate and going clockwise. This takes them about 10 minutes, after which they'll go off to the hall again.

Getting In

The runners have several options to get in. They will undoubtedly come up with others, but some of the more obvious ones are included here, together with the guards' reactions, if any.

Over The Wire: Climbing the fence is a definite possibility, but also one where the runners might get stuck or wounded on the razorwire. The runners must make two Athletics skill tests, using the Climbing concentration if they have it, against a target number 6. The first test is to climb up the wire, the second is to climb down on the other side. See the table below for the results of the test; against all damage from this table, impact armor can be used.

Successes	Result
0	The runner falls down on the side he or she was climbing, taking $(1D6 \div 2)D$ damage (roll 1D6, divide by 2 and round up, and use that as the Power Level of the "attack")
1	The runner gets stuck and takes 4M damage trying to free him- or herself from the wire
2	The runner gets stuck and takes 5L damage trying to free him- or herself from the wire
3+	The runner climbed the fence over successfully

An alternative, if the team's magician has a Levitate Person spell, is to use that. The camp's defenses don't really have anything to stop someone coming in this way, except by shooting at them if they're spotted, so this is probably the easiest way in.

Through The Wire: If they have a wirecutter, the runners can cut the concertina wire and the fence to get in more easily. However, the guards that walk around the perimeter every hour will notice the cut fence when they reach it. They will raise the alarm within one minute of finding the hole in the fence.

Knocking At The Door: The stupidest thing they can do, as the guards will not let them in, or even open the gate for them, under any condition, and the guards will now also be alerted to the presence of possible intruders. By the way, unless someone among the runners speaks Russian, they have no hope of communicating with the guards.

Magicians with a Control Thoughts, Influence, or Mob Mind spell may want to use this to get the guards to open the gate. The gamemaster should judge the feasibility of such a plan, but as before, seeing that the camp has no magical defenses the only barrier to overcome with this approach is the guards' Willpower.

Taking Out The Guards: This is a definite option, but unless done silently the rest of the camp will be warned to the runners' approach. Taking out tower guards is a problem because they're up in the towers, out of melee reach. Spells or silenced firearms have no problem with that, though remember there are multiple guards at the gates who will have to be taken out in very rapid succession to prevent them from sounding the alarm and/or returning fire.

Knocking out the guards patrolling the fence is also possible, but the guards in the main hall will get suspicious if the foot patrol stays out too long; if they're not back 15 minutes after they started out, the other guards will investigate. Needless to say, the discovery of unconscious or dead bodies will lead to the alarm being raised.

Walking Around In The Camp

Being inside the camp can lead to detection as well. Since this is a small and very closed community, everyone knows everyone, and outsiders rarely arrive without everybody knowing about it. During the day, the people living in the camp are walking around, working, and so on, and for this reason, should the runners walk around in the camp during the day, they will be identified as intruders in 1D6 minutes. This will happen even if they're dressed up as guards, since everybody knows the faces of the real guards.

At night, hardly anyone ventures outside except when absolutely necessary, like for going to the toilet. There is a chance the runners encounter guards, but this is up to gamemaster's discretion based on where the runners are and whether it is time for the guards to do their round or not. However, if the runners look like they don't belong in the camp (going by their clothes), they will automatically be seen as hostiles and the alarm raised. If the runners decided to dress up as Kazakhstan natives, the guards (or camp inhabitants) get a Perception (3) test to identify the runners; increase the target number to 5 if they're dressed up as camp guards.

The runners' best move is to get to the silo entrance ASAP once they're inside the fence, though. Remember that the camp's inhabitants are all survivalists, which means that even the children know how to use firearms and are continually being trained in small-unit tactics. Nearly everyone has at least one weapon in their homes, and though many of these are old-fashioned, they can still be used to kill people very effectively. Should the players start a major firefight, then everybody in the camp jumps in. (Arm them with whatever seems likely, keeping in mind these people don't have the latest hi-tech weapons from North America at their disposal. Their armament will be mainly pistols, SMGs, assault rifles, and sporting rifles, plus the odd shotgun, LMG, grenade launcher, and other weapons.)

Getting Captured

Runners stupid enough to get captured by the camp's population will be questioned for at least a day about their reasons to enter the camp. Metahumans and anyone who appears to be a magician will be treated more roughly than the others, but the interrogations aren't pleasant for anyone. Prisoners are locked up in a strong room in the main hall, constructed from metal sheeting and with windows too small to crawl through.

The runners should get a chance to escape, but the chance shouldn't be too obvious and they should get away only if they do it sensibly — everyone in the camp knows there was an attempted break-in (or "invasion" as they refer to it) and is on guard.

Anyone left in the camp's prison after the interrogation will be scheduled for public execution the next day (they will be told about this by one of the prison guards who speaks English), but the insect shaman from the hive in the silo will argue with the survivalist leaders about taking the prisoners into the silo complex, promising they won't bother the camp any longer if he is allowed to take care of them. In the end, the leaders give in, and the players are dropped off in the silo entrance (room 1 on the silo map). Once the camp guards have left, termite spirits take the runners into the silo and put them into cocoons to invest them with an insect spirit. Smart runners may get a chance to escape here as well, but if they don't take it, it'll be the end of the characters as everyone knows them...

The Silo Complex

The complex consists of six structures, connected to each other by tunnels. Unless otherwise noted, all buildings have concrete walls about 3 meters thick (giving them a Barrier Rating is unnecessary), while the doors are 15 cm thick steel, Barrier Rating 50 and equipped with handwheels to lock and

unlock them. (Hey, this is a nuclear missile silo — it's built to withstand the enemy's nukes for long enough to launch its own ICBM.) It is virtually impossible for players to blast their way in with explosives, although there is no need to tell them that before they try. Have them wake up the whole camp if they want to try... Inside, light is provided by tube lights on the ceiling, behind metal grates. This makes it hard to knock them out with the butt of a rifle, for example, but an explosion or area-effect physical combat or damaging manipulation spell will shatter the tubes (since this is underground, darkness is *absolutely* dark. Low-light systems won't work unless there's some background light, and so it's useless once the lights are out in a room or corridor, unless someone has a flashlight).

All ceilings are 2½ meters above the floor, by the way. When this facility was built, there weren't any trolls to take into account...

If a fight breaks out in the silo complex, the guards on the outside will not be alerted to it, except if there is gunfire in the entrance (room 1) or the upper part of the stairwell. Sounds from the rest of the complex don't carry to the camp, and the insect spirits will under no circumstance call for help to the survivalists, for obvious reasons.

Magic

Most of the inside of the complex has a background count of 1, except for the first half of the stairwell and the entrance at the top (room 1 on the map), which has a background count of 0. The silo itself (room 6) has a background count of 2, as this is where the main hive is located.

Keep in mind that it is impossible to enter the facility through astral space except by defeating one of the wards placed in the stairwell and silo (see the room descriptions below), because the natural earth around the rooms and corridors blocks all astral passage. Only room 1 and the first few meters of the stairwell can be entered from astral space.

Insect Spirits

This particular hive houses termite spirits, described on page 105 of the *Grimoire*. The two shamans have not yet summoned a queen, so the number of spirits is still limited to about 15 true forms and 35 flesh forms. (Information about insect spirits and their abilities in general appears in the *Grimoire II* on pages 101 through 107, and also on pages 138 through 144 of *Bug City*.)

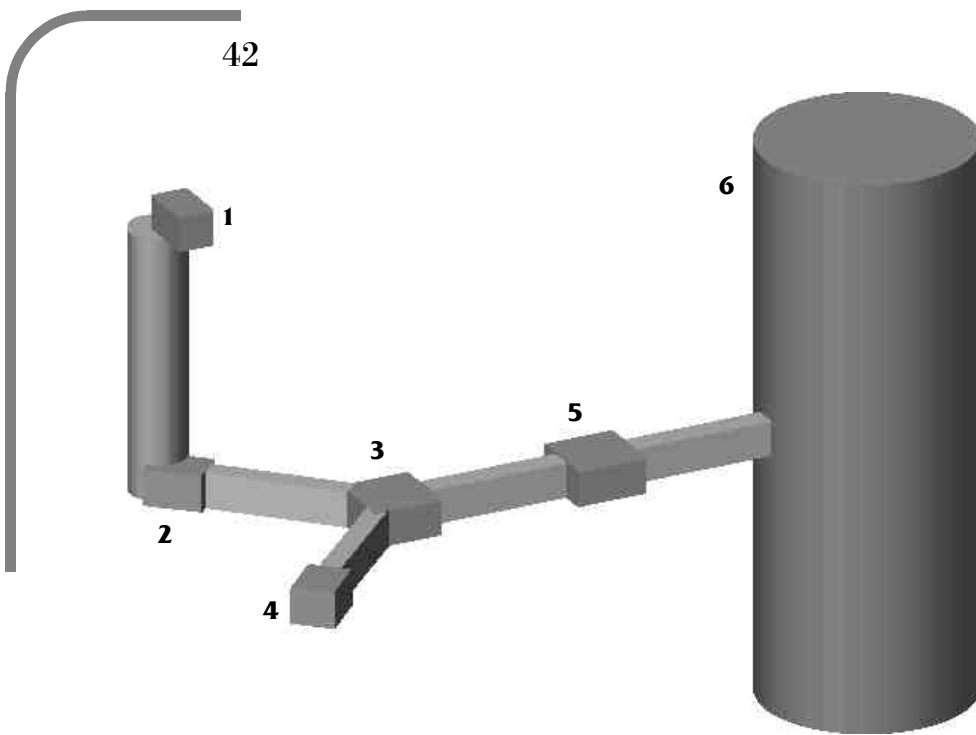

Stairwell Entrance (1)

This small subterranean room is about 2½ x 4 meters, and has a door at one end and a spiral staircase going down through a hole in the floor opposite the door. There is a railing around the staircase to prevent people falling in, but apart from that the room is bare.

The door is only normal steel plate, Barrier Rating 10 with an old-fashioned mechanical lock, rating 4 (see *All That Is Old Is Not Obsolete* in *NERPS: Underworld*); this door is obviously a replacement for whatever door was protecting the bunker originally. Outside the door are concrete steps between two thin concrete walls, leading up to ground level.

The spiral staircase leads down for some 20 meters, although the distance is very hard to tell because there are little or no remarkable features anywhere on the steel stairs or the concrete walls.

Some 3 meters from the top of the stairs is a Force 9 ward (*Grimoire II* page 92) to keep out astral intruders; if *Paranoid Animals of North America* is available¹ make it a Serious-damage ward. (In short, the ward causes Serious damage rather than Light to anyone trying to get through, otherwise it uses the normal ward rules from the *Grimoire*.) If characters attempt to take active magical foci along with them while passing through the ward, refer to the *Resolving Astral Combat, Barriers and Magical Items* sections on pages 147 and 148 of *SR11*. Since the ward does Serious damage that might result in a few charred foci, but a magician who spotted the ward through astral perception can turn off his or her foci before going through the ward, which prevents them from being attacked by it. Attacking the war in any way alerts the insect shaman (who set it) to the runners.

The staircase is only wide enough to walk in single file, so ask the players in which order their characters descend the stairs, as this may become important later on. The staircase isn't in perfect repair and is occasionally difficult to walk on. Call for a Quickness (4) test once or twice, anyone who fails falls down the stairs and gets to make a Body test against 6M Stun damage (impact armor protects). If there are others further down on the stairs, they must make a Reaction test to avoid

¹ If not, *why* not? :) <shameless plug> Check out <http://www.xs4all.nl/~gurth/pw/shadowrun.html> </shameless plug>

being dragged along by the falling character. The target number is 3 plus the number of people above the character who also have fallen. Should the Reaction test fail, the character falls and takes 6M Stun damage as well.

The further down the characters go, the hotter it gets in the stairwell. About half-way down, they will start to notice the temperature inside rising, and by the time they're all the way down it's about 30 degrees, though it seems a lot more than that due to the humidity inside.

Another thing the runners will notice when they get further than three-quarters down the staircase is that the walls and stairs get a yellowish tint. By the time they're all the way down, there's a thin layer of sand-colored goo over everything. Let them make a Quickness (5) test to see if they slip; handle the results as above. Any surface covered in this goo counts as difficult ground during combat

At the very bottom of the stairs is a small room with a door; the door is not covered in goo, unlike the rest of the room, and gives access into the bunker entrance, number 2 on the silo map and described directly below.

Bunker Entrance (2)

This is another bare room, some 3 by 4 meters in size. It is covered in the yellow goo as well. Two true form and one flesh form termite spirit are on guard here. They will attack anyone coming through the door leading to the staircase, but will not open the door or follow anyone fleeing up the staircase — they have orders to wait for intruders and not pursue them. Astral intruders will be attacked by one of the true form spirits; if there are no astral intruders, both the flesh-form spirits manifest on the physical plane.

Flesh Form Termite Soldier (one, Force 2)

B	Q	S	C	I	W	E	R	Armor	Attacks
5	4 x3	5	—	2	2	(2)	5	0/0	5M

Initiative: 5+1D6

Threat/Professional Rating: 2/4

True Form Termite Soldier (two, Force 3)

B	Q	S	C	I	W	E	R	Armor	Attacks
4	7 x4	8	—	3	2	(3)	6	3/3	8M or Special

Initiative: 16+1D6 when physically manifest, 26+1D6 in astral space

Threat/Professional Rating: 3/4

Powers: Enhanced Senses (Smell), Paralyzing Touch, Venom

Weaknesses: Reduced Senses (Sight), Vulnerability (Insecticides)

Bunkroom (3)

This room was once the place where the missile crew slept, prepared and ate their meals, and so on. It has been stripped clean of all equipment that once was in it, and is now covered in the yellow goo that seems to be everywhere in the facility. The room is therefore just a bare concrete box with goo in it. Runners entering it will be confronted by more termite spirits coming up to prevent the intruders from getting to the main hive, located in the actual silo (room 6).

Generator and Computer Room (4)

This is the room the runners came for. The left-hand wall is covered by a large, old-fashioned computer, while against the back wall is a desk with an office chair. There is an access panel in one of the walls; behind this is the complex's generator. The original one was taken away by the survivalists when they first set up camp, so the insect shaman, when he took over the complex, had to install a new one. Anyone looking behind the access panel will notice that the current generator is obviously not part of the original equipment. It can quite easily be disconnected by cutting a few cables, plunging the whole complex into darkness.

The players will have to look for the computer core, which takes a few minutes to find. Once found, a screwdriver is sufficient to remove it — unfasten a screw at each corner of the panel, slide it out of the computer, then disconnect a few cables, and the job is done. The thing weighs almost 25 kg and is about the size of a small briefcase.

However, before things will get this far, there are three more flesh form spirits to deal with, which have been locked in here by the shaman to keep them out of the way for the moment. They attack anyone venturing into the room except for other insect spirits or the hive's shaman.

Flesh Form Termite Soldier (three, Force 2)

B	Q	S	C	I	W	E	R	Armor	Attacks
5	4 x3	5	—	2	2	(2)	5	0/0	5M

Initiative: 5+1D6

Threat/Professional Rating: 2/4

This room is not covered in the yellowish goo, but is very dusty. The recent trampling around of the three flesh form spirits has swept most of the dust on the floor and desk aside, though.

Control Room (5)

Once functioning as the nerve center of the *Demon* ICBM complex, this is now in use as the insect shaman's private quarters. The control panels are all still there, but they don't work anymore as their insides have been gutted. A bunk bed, a footlocker and a desk that originally were part of room 3's equipment are now here for the shaman to use. There aren't many useful things to be found in the room, even though there is a lot of stuff around. The shaman is not here at the time the runners enter.

Demon Silo (6)

The largest of the complex's structures is the missile silo, which is about 40 meters deep and 7½ meters in diameter at the top, narrowing to 6 meters at the bottom. Its walls are thicker still than those of the bunkers, and at the top is a sliding concrete and steel cover that is currently closed. It cannot be opened because the replacement generator installed by the insect shaman and spirits cannot generate sufficient power. The cover is about 3 meters thick, and a ward like that protecting the staircase (see **Entrance**, above) is in place in the center of the cover: anyone trying to get through on the astral plane will get about halfway through and then hit the ward.

The inside of the silo has launch control mechanisms, but the missile has been removed when the silo was decommissioned as a military installation. The termite spirits have set about extensively rebuilding the interior, but so far haven't altered the outside walls or gone through them. The insides are basically one big, three-dimensional maze of walls, floors, and ceilings that don't follow any design apparent to humans. To get anywhere will mean crawling through holes in the various surfaces that form the rooms; there are no ladders

or stairs of any kind inside except those installed as part of the original silo equipment — and they're found only near the outside walls.

It is possible to knock holes in the walls; they have a Barrier Rating equal to the result of 1D6; apply the Rule of Six to this roll. Sadistic gamemasters may want to roll for the floor of each room as well, letting the runners fall through if the Barrier Rating is too weak to support them.

At several points in the maze are larger rooms where termite spirits have gathered. The shaman is in one of these rooms, but he will flee into the maze if the runners enter it. All the time they crawl through the maze, the runners are harassed and attacked by termite spirits. Every spirit which spots the runners will attempt to attack them, even the workers (which are very poor fighters). Use the statistics on page 105 of the *Grimoire II* for these spirits.

Exfiltration

Once the runners have the computer core, or decide it isn't worth risking their life for, they have to get out of the camp. This will be at least as hard as getting in, and a lot harder if they managed to put the camp on alert before or during their entry into the silo. The termite spirits will pursue the runners up the staircase, but will not go beyond the ward in order not to be spotted by the survivalists.

At the gamemaster's discretion, once out of the camp, the runners may be chased all the way to the plane by the survivalists; the more trouble the runners caused, the greater the chance that they will be pursued. When they get to the plane, the pilots start it up and prepare to take off. If the runners are being followed by the survivalists, this can make for some tense moments—will the plane make it into the air without getting too many holes in it?

Back To Seattle

The return flight also takes about 28 hours, and nothing much happens during this time either, assuming the plane is still in airworthy condition. If not, it could be the start of another adventure in which the runners try to get back to Seattle from somewhere in Asia.

At any rate, once the runners are home they can make the drop-off at the bus station and collect their payment. This part of it is in Tir Tairngire nuyen bills, in an old sports bag sitting in the locker. (This is partly to throw the runners off Winternight's track, because they may assume their employers were from the Tir, and partly because Tir Tairngire citizens still use hard currency for small transactions a lot, so the country is a relatively easy source of untraceable money.)

Karma Awards

Threat	2
Retrieving the computer core	2
Killing the insect shaman	1
Not handing the core to Winternight	2

Note that if the players decide not to hand the core to Winternight, they'll get more Karma (don't tell them this in advance) but they also get a pissed-off Winternight cell after them, wanting to get both the computer core and the runners' heads. They'd better be *very* good at hiding if this happens, as even if they hand the core over later on Winternight will probably kill them outright for attempting to cross them.